

GC4014

QUAD RECEIVER CHIP

DATASHEET

April 27, 1999

Rev 0.5

This datasheet contains information which may be changed at any time without notice.

REVISION HISTORY

Revision	Date	Description
0.0	1 Dec. 1997	Original
0.1	14 Jan 1998	Page iii, added mask revision table to list of tables Pages 8, last line, added non-symmetry mode errata Page 10, footnote, changed "1 milliseconds" to "10 microseconds". Page 11, modified Figure 10 (c) Page 12, first line Section 3.7, changed "output" to "input". Page 18, address 1, bit 6, added non-symmetry errata Page 19, address 4, bits 4-7, corrected bit assignments Pages 20-21, corrected address numbering for blanking and flush registers Page 22, address 12, bits 0,1, changed "12 LSBs" to "14 LSBs". Page 24, address 16, added mask revision table. Throughout, corrected table and figure reference
0.2	21 Jan 1998	Page 30, Changed data setup time from 4 to 2 ns. Page 8, 18 Non-symmetry mode works for parts marked with all mask codes except 55532B Page 24, Changed Table 5 to add mask code 55532C Page 28, Table 7 min and max recommended Vcc changed to 3.1 to 3.5 volts. Page 28, Table 7 max junction temperature changed to 125C.
0.3	5 Feb 1998	Page 38, Changed 800 to 8000 in Table 17. Page 38, Changed E5 to EA in note 1, Table 16. Page 37, Checksum for test4 changed to D2.
0.4	23 Apr 1999	Page 38, Changed CS to CE in the control interface timing description, Table 10 Pages 9,19, Changed GAIN equation from "NARROW*1.97" to "NARROW*0.97 + 1" Page 28, Table 7, Changed max Vup voltage to 5.5v. Page 39, New gain application note. Pages 5, 25, Positive frequency to downconvert. Pages 36, 37, changed 26 -> 2A for address 00 Page 29, Table 9, changed V _{IH} for CK, CK2X to 2.4V from 2.0V. Page 29, Table 9, changed I _{OH/L} to +/- 4mA from 2.0mA Page 30, F _{CK} changed to 64MHz, clock to output changed to 20ns.
0.5	27 Apr 1999	Pages 9,19,33,35,39, changed gain equation G/64 -> G/32
0.6		Pages 6, 38 changed 55 to 56 in gain equations.

1.0	KEY FEATURES	1
2.0	BLOCK DIAGRAM	1
3.0	FUNCTIONAL DESCRIPTION	2
3.1	CONTROL INTERFACE	2
3.2	INPUT FORMAT	3
3.3	THE DOWN CONVERTERS	4
3.4	FINAL GAIN ADJUSTMENT	9
3.5	SUMMATION MODES	9
3.6	OUTPUT MODES	10
3.7	CLOCKING	12
3.8	POWER DOWN MODES	12
3.9	SYNCHRONIZATION	12
3.10	DATA LATENCY	13
3.11	DIAGNOSTICS	13
4.0	PACKAGING	14
5.0	CONTROL REGISTERS.....	16
5.1	SYNC MODE REGISTER	17
5.2	DECIMATION MODE REGISTER.....	18
5.3	CIC DECIMATION REGISTERS.....	18
5.4	SCALE CONTROL REGISTER.....	19
5.5	CHANNEL GAIN REGISTER.....	19
5.6	OUTPUT FORMAT REGISTER	20
5.7	OUTPUT MODE REGISTER.....	20
5.8	BLANKING CONTROL REGISTER	20
5.9	CHANNEL FLUSH CONTROL REGISTER.....	21
5.10	COUNTER MODE REGISTERS	21
5.11	TEST MODE REGISTER	22
5.12	PAGE MAP REGISTER	22
5.13	STATUS CONTROL REGISTER	23
5.14	CHECKSUM REGISTER.....	23
5.15	CHANNEL OUTPUT PAGE (PAGE = 0).....	24
5.16	KEEPALIVE STATUS PAGE (PAGE = 1).....	24
5.17	CHANNEL CONTROL PAGES (PAGES 4, 5, 6, 7).....	25
5.18	COEFFICIENT STORAGE PAGES (PAGES 8, 9, 10 and 11).....	27
6.0	SPECIFICATIONS	28
6.1	ABSOLUTE MAXIMUM RATINGS	28
6.2	RECOMMENDED OPERATING CONDITIONS.....	28
6.3	THERMAL CHARACTERISTICS	28
6.4	DC CHARACTERISTICS	29
6.5	AC CHARACTERISTICS.....	30
7.0	APPLICATION NOTES.....	31
7.1	POWER AND GROUND CONNECTIONS.....	31
7.2	STATIC SENSITIVE DEVICE.....	31
7.3	SYNCHRONIZING MULTIPLE GC4014 CHIPS	31
7.4	THERMAL MANAGEMENT.....	31
7.5	GSM APPLICATION.....	32
7.6	DAMPS APPLICATION	34
7.7	DIAGNOSTICS.....	36
7.8	OUTPUT TEST CONFIGURATION	38
7.9	OPTIMAL GAIN SETTINGS	39

LIST OF FIGURES

Figure 1:	GC4014 Block Diagram	1
Figure 2:	Control I/O Timing	3
Figure 3:	The Down Converter Channel.....	4
Figure 4:	NCO Circuit.....	5
Figure 5:	Example NCO Spurs.....	5
Figure 6:	NCO Peak Spur Scan Plot.....	6
Figure 7:	Four Stage CIC Decimate by N Filter.....	6
Figure 8:	Combined CFIR and CIC Frequency Response	7
Figure 9:	Overall CIC-CFIR-PFIR Response	8
Figure 10:	Serial Output Formats	11
Figure 11:	Overall Frequency Response for GSM	32
Figure 12:	Overall Frequency Response for DAMPS.....	34

LIST OF TABLES

Table 1:	Output Summation Modes	9
Table 2:	TDM Modes.....	10
Table 3:	Latency.....	13
Table 4:	Sync Modes	17
Table 5:	Mask Revision History.....	24
Table 6:	Absolute Maximum Ratings	28
Table 7:	Recommended Operating Conditions	28
Table 8:	Thermal Data	28
Table 9:	DC Operating Conditions	29
Table 10:	AC Characteristics (-40 To +85C Ambient, unless noted)	30
Table 11:	GSM Configuration.....	33
Table 12:	DAMPS Configuration	35
Table 13:	Diagnostic Test 1 Configuration	36
Table 14:	Diagnostic Test 2 Configuration	36
Table 15:	Diagnostic Test 3 Configuration	37
Table 16:	Diagnostic Test 4 Configuration	37
Table 17:	Output Test Configuration	38
Table 18:	Test Output Sequence	38

GC4014 DATASHEET

1.0 KEY FEATURES

- Input rates up to 64 MSPS
- Four real input down-convert channels or Two complex input downconvert channels
- Independent tuning frequencies
- Independent phase/gain controls
- 4 by 4 14 bit Input Crossbar switch or 3 by 4 16 bit Input Crossbar switch
- Decimation factors of
 - 16 to 32,768 in the real output mode
 - 32 to 65,536 in the complex output mode
- Zero padding for lower decimation factors
- Outputs can be either:
 - bit serial,
 - nibble serial (link port)
 - or memory mapped
- Output summing for beamforming
- 8 to 16 bit output samples
- 0.02 Hz tuning resolution
- 0.14 dB gain resolution
- Less than 0.05 dB peak to peak passband ripple
- Greater than 100 dB far image rejection
- Greater than 95 dB spur free dynamic range
- User programmable 63 tap output filter
- Nyquist filtering for QPSK or QAM symbol data
- Meets GSM, AMPS and DAMPS Cellular specifications
- Microprocessor interface for control, output, and diagnostics
- Built in diagnostics
- Microprocessor interface will accept either 3.3 or 5 volt input levels
- 250 mW per channel at 50 MHz, 3.3 volts
- 100 pin thin QFP package

2.0 BLOCK DIAGRAM

A block diagram illustrating the major functions of the chip is shown in Figure 1.

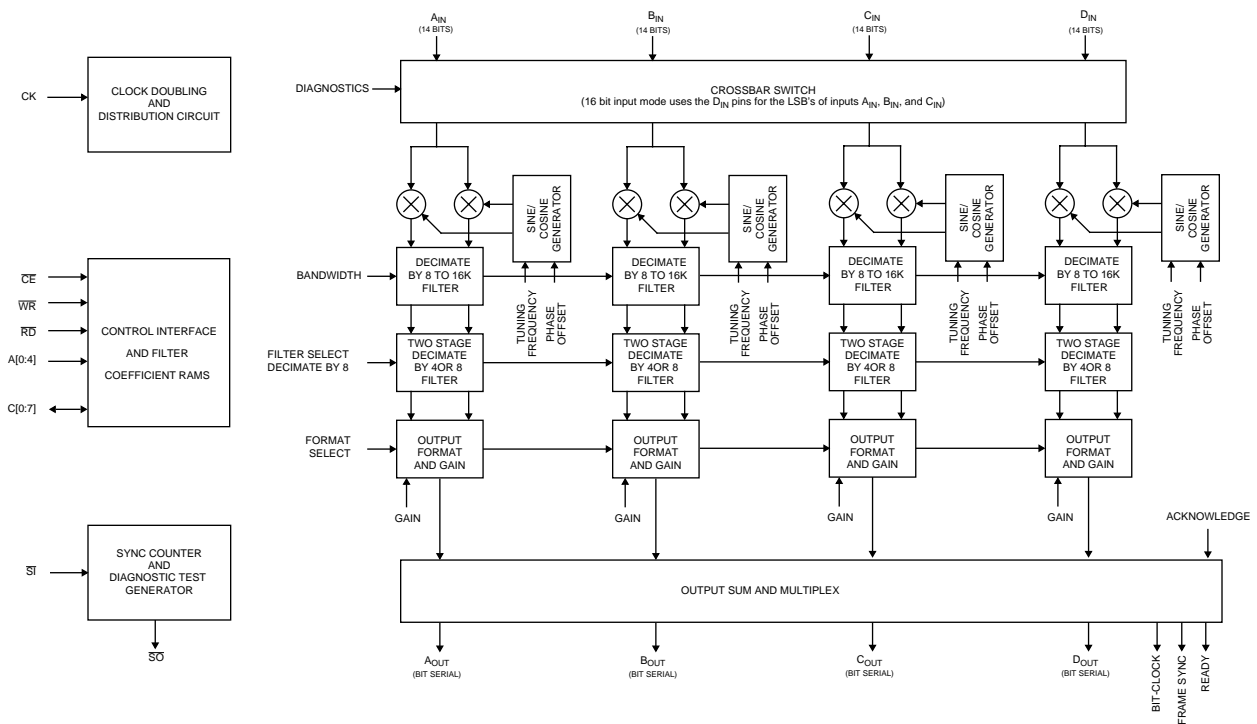

Figure 1. GC4014 Block Diagram

3.0 FUNCTIONAL DESCRIPTION

The GC4014 quad receive chip contains four identical down-conversion circuits. Each down-convert circuit accepts a real sample rate up to 62.5 MHz, down converts a selected carrier frequency to zero, decimates the signal rate by a programmable factor ranging from 16 to 32768 (32 to 65,536 for complex outputs), and optionally sums it with other down converted samples. The chip outputs the four down-converted signals, or their sum. The chip contains a user programmable output filter which can be used to arbitrarily shape the received data's spectrum. This filter can be used as a Nyquist receive filter for digital data transmission.

Two down-converter paths can be merged to be used as a single complex input down-conversion circuit.

The down-converters are designed to maintain over 95 dB of spur free dynamic range and over 100 dB of out of band rejection. Each down-convert circuit accepts 16 bit inputs and produces 16 bit outputs (bit serial). The frequencies and phase offsets of the four sine/cosine sequence generators can be independently specified, as can the gain of each circuit. The down converters share the same bandwidth, filter coefficients and input formats. A special mode allows the downconverters to support GSM and DAMPS blocker requirements (see Sections 7.5 and 7.6).

On chip diagnostic circuits are provided to simplify system debug and maintenance.

The chip receives configuration and control information over a microprocessor compatible bus consisting of an 8 bit data I/O port, a 5 bit address port, a chip enable strobe, a read strobe and a write strobe. The chip's control registers (8 bits each) are memory mapped into the 5 bit address space of the control port.

Section 7.5 Describes a typical application, including control register values and the proper sequence of operations required to use the chip.

3.1 CONTROL INTERFACE

The chip is configured by writing control information into sixty four control registers within the chip. The contents of these control registers and how to use them are described in Section 5. The registers are written to or read from using the **C[0:7]**, **A[0:4]**, $\overline{\text{CE}}$, $\overline{\text{RD}}$ and $\overline{\text{WR}}$ pins. Each control register has been assigned a unique address within the chip. This interface is designed to allow the GC4014 to appear to an external processor as a memory mapped peripheral (the pin $\overline{\text{RD}}$ is equivalent to a memory chip's $\overline{\text{OE}}$ pin).

An external processor (a microprocessor, computer, or DSP chip) can write into a register by setting **A[0:4]** to the desired register address, selecting the chip using the $\overline{\text{CE}}$ pin, setting **C[0:7]** to the desired value and then pulsing $\overline{\text{WR}}$ low. The data will be written into the selected register when both $\overline{\text{WR}}$ and $\overline{\text{CE}}$ are low and will be held when either signal goes high.

To read from a control register the processor must set **A[0:4]** to the desired address, select the chip with the $\overline{\text{CE}}$ pin, and then set $\overline{\text{RD}}$ low. The chip will then drive **C[0:7]** with the contents of the selected register. After the

processor has read the value from **C[0:7]** it should set $\overline{\text{RD}}$ and $\overline{\text{CE}}$ high. The **C[0:7]** pins are turned off (high impedance) whenever $\overline{\text{CE}}$ or $\overline{\text{RD}}$ are high or when $\overline{\text{WR}}$ is low. The chip will only drive these pins when both $\overline{\text{CE}}$ and $\overline{\text{RD}}$ are low and $\overline{\text{WR}}$ is high.

One can also ground the $\overline{\text{RD}}$ pin and use the $\overline{\text{WR}}$ pin as a read/write direction control and use the $\overline{\text{CE}}$ pin as a control I/O strobe. Figure 2 shows timing diagrams illustrating both I/O modes.

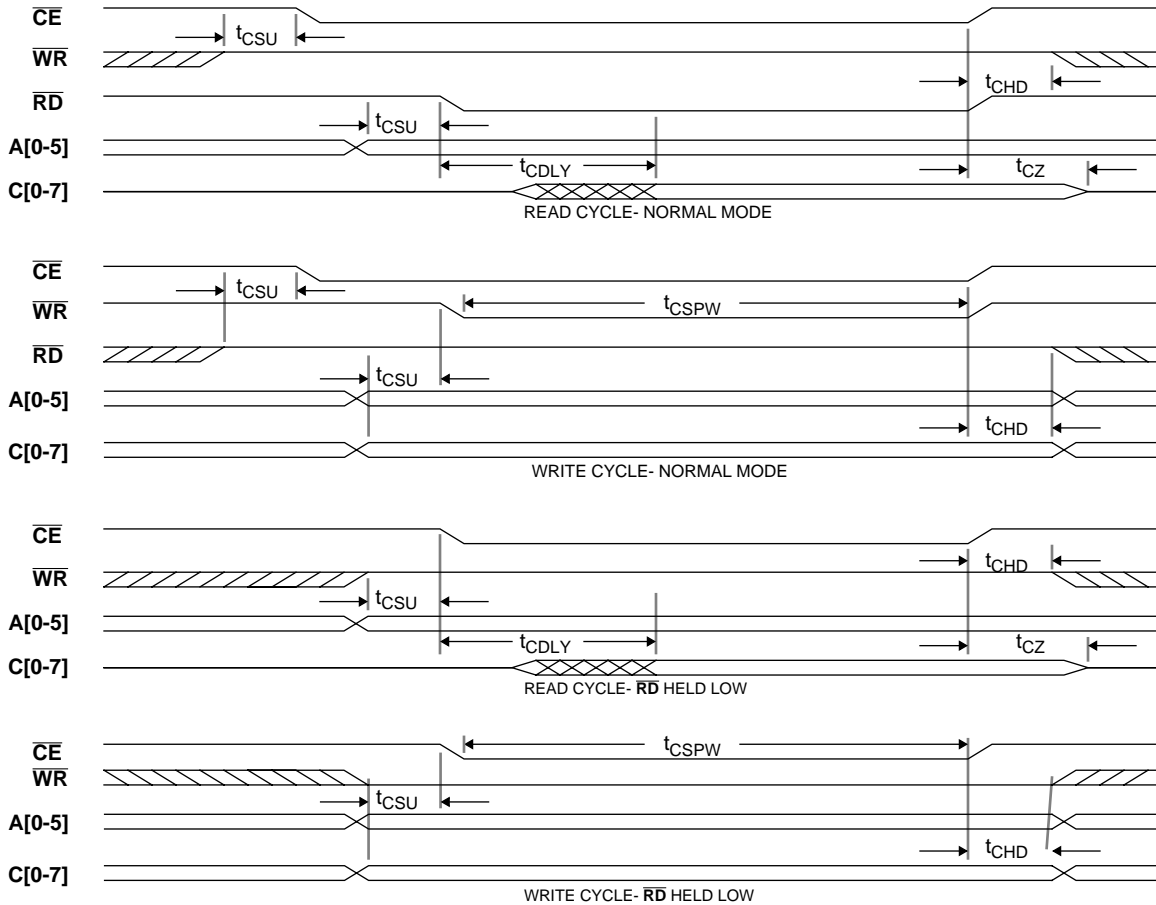

Figure 2. Control I/O Timing

The setup, hold and pulse width requirements for control read or write operations are given in Section 6.0.

The **C**, **A**, $\overline{\text{WR}}$, $\overline{\text{RD}}$ and $\overline{\text{CE}}$ pins will accept either 5 volt or 3.3 volt input levels. A separate power supply voltage pin (**V_{UP}**) is provided on the chip to enable this feature.

3.2 INPUT FORMAT

Both 14 bit and 16 bit input formats are accepted. In the 14 bit mode the inputs are 14 bit samples from four different sources. In the 16 bit mode, the inputs are 16 bit samples from three different sources. In either case, a crossbar switch allows the user to route any input to any down-converter channel. The input samples are normally clocked into the chip at the clock rate, i.e., the input sample rate is equal to the clock rate. Input rates lower than the clock rate can be accepted by using the zero pad mode. The zero pad mode will insert up to 15 zeroes between

each input sample, allowing input data rates down to 1/16th the clock rate. Zero padding also lowers the effective decimation ratio. For example, the minimum decimation is normally factor of 32. If the input data rate is 5 MSPS and the chip can be clocked at 40 MHz, then the zero pad function can be used to pad the 5 MSPS input data up by a factor of 8 to 40 MSPS. The minimum decimation of 32, once the zero padding is done, becomes a minimum decimation of 4 relative to the original 5 MSPS data.

3.3 THE DOWN CONVERTERS

Each down converter uses an NCO and mixer to quadrature down convert a signal to baseband and then uses a 4 stage CIC¹ filter and a two-stage decimate by 4 or 8 filter to lowpass filter and to isolate the desired signal. A block diagram of each filter is shown below:

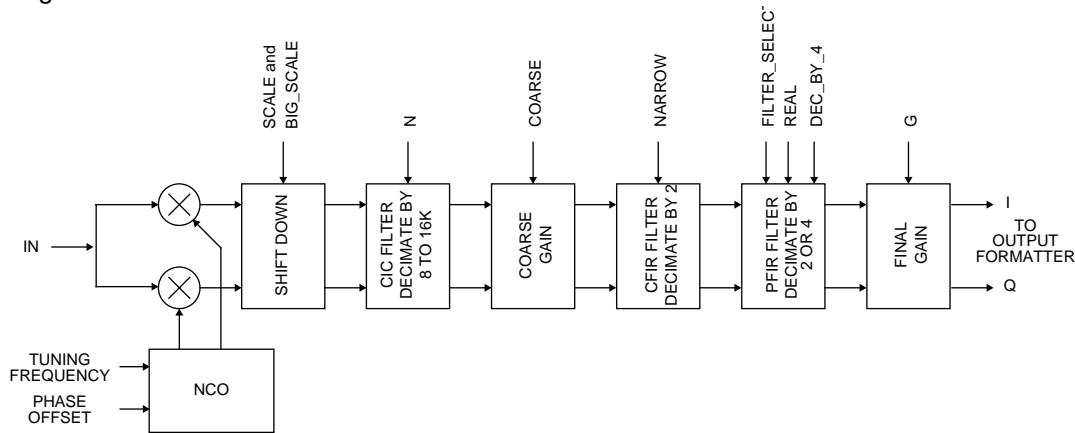

Figure 3. The Down Converter Channel

The CIC filter reduces the sample rate by a programmable factor ranging from 8 to 16,384. The CIC outputs are followed by a coarse gain stage and then followed by a two stage decimate by 4 or 8 filter. The coarse gain circuit allows the user to boost the gain of weak signals up to 42 dB in 6 dB steps. The first stage of the two stage filter is a compensating 21 tap decimate by 2 filter (CFIR) with a choice of two sets of fixed tap weights. The first set is designed to be flat from $-0.5F_S$ to $+0.5F_S$, where F_S is the output sample rate, and to reject out of band energy by at least 80dB. The second set has a narrower output passband ($-0.25F_S$ to $+0.25F_S$), but more out of band rejection. The second set is ideal for systems such as GSM, which require more far band rejection (>97 dB), but with relaxed adjacent band rejection. The second stage is a 63 tap decimate by 2 or 4 programmable filter (PFIR) with either internal or user supplied tap weights. The internal filter is designed to be flat from $-0.4F_S$ to $+0.4F_S$ of the output sample rate and to reject out of band energy by at least 85 dB. The user can also design and download their own final filter to customize the channel's spectral response. Typical uses of the programmable filter include matched (root-raised cosine) filtering, or filtering to generate oversampled outputs with greater out of band rejection. The 63 tap symmetrical filter is downloaded into the chip as 32 words, 16 bits each. The programmable PFIR coefficients must be used to bandlimit the output in the decimate by 4 mode.

1. Hogenauer, Eugene B., An Economical Class of Digital Filters for Decimation and Interpolation, IEEE transactions on Acoustics, Speech and Signal Processing, April 1981.

The PFIR will also, if desired, convert the complex output data to real. The complex to real conversion also doubles the output sample rate so that the PFIR decimation is 1 or 2 in the real mode.

The PFIR filter is followed by a gain and output format circuit. The gain circuit allows the user to add an additional 18 dB of gain in 0.14 dB steps. The output format circuit can also delete every other sample without filtering. Anti-aliasing filtering must have already been performed (in the second stage filter). This is useful to achieve deeper far-band rejection since the stopband performance of the CIC filter is a function of the decimation that follows it.

3.3.1 The Numerically Controlled Oscillator (NCO)

The tuning frequency of each down converter is specified as a 32 bit word and the phase offset is specified as a 16 bit word. The NCOs can be synchronized with NCOs on other chips. This allows multiple down converter outputs to be coherently combined, each with a unique phase and amplitude. A block diagram of the NCO circuit is shown in Figure 4.

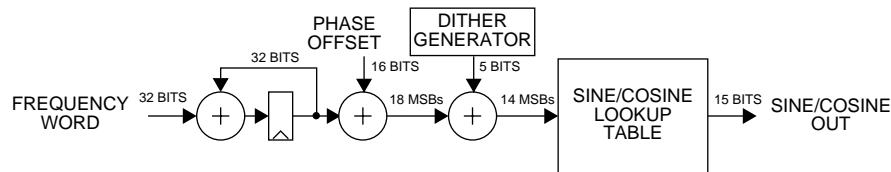

Figure 4. NCO Circuit

The tuning frequency is set to $FREQ$ according to the formula $FREQ = 2^{32}F_{CK}$, where F is the desired tuning frequency and F_{CK} is the chip's clock rate. The 16 bit phase offset setting is $PHASE = 2^{16}P/2\pi$, where P is the desired phase in radians ranging between 0 and 2π . Note that a positive tuning frequency is used to downconvert the signal. A negative tuning frequency can be used to upconvert the negative image of a real signal (inverting the spectrum).

The NCO's spur level is reduced to below -92 dBc through the use of phase dithering. The spectrums in Figure 5 show the NCO spurs for an example tuning frequency before and after dithering has been turned on. Notice that the spur level decreases from -82 dB to -105 dB.

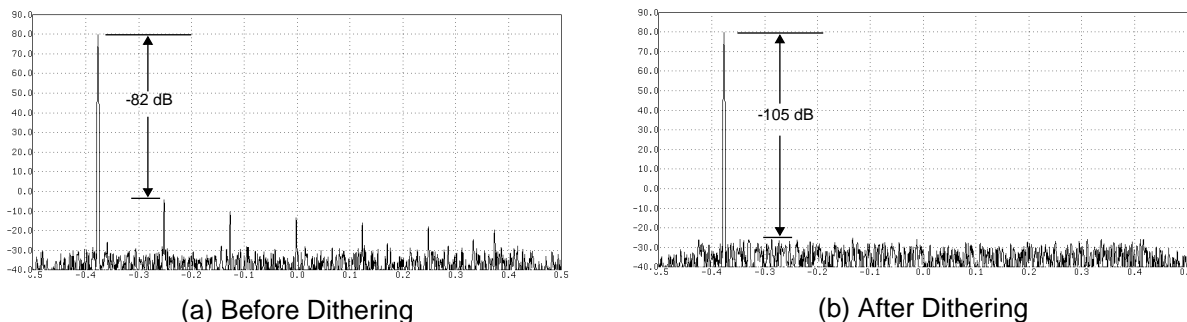

Figure 5. Example NCO Spurs

Figure 6 shows the maximum spur levels as the tuning frequency is scanned over a portion of the frequency range with the peak hold function of the spectrum analyzer turned on. Notice that the peak spur level is -82 dB before dithering and is between -92 and -102 after dithering has been turned on.

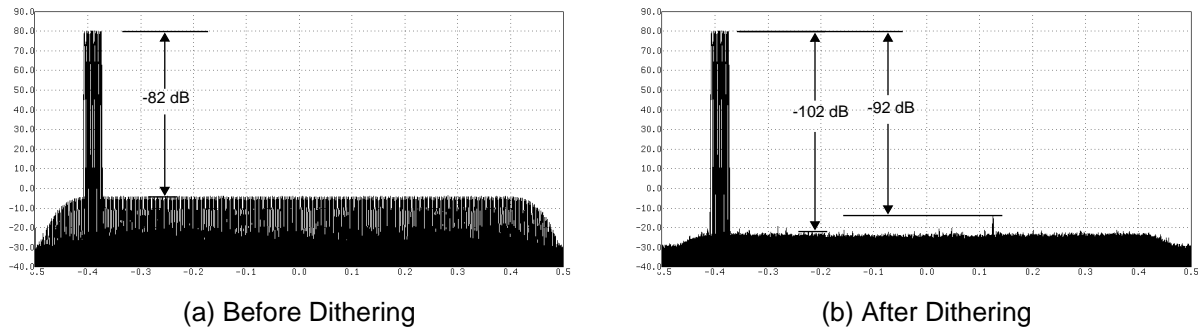

Figure 6. NCO Peak Spur Scan Plot

The worst case NCO spurs at -92 dB, such as the one shown in figure 6(b), are due to a few frequencies that are related to the sampling frequency by small rational numbers (for example $FREQ = 3/16 * F_{ck}$). In these cases the rounding errors in the sine/cosine lookup table repeat in a regular fashion, thereby concentrating the error power into a single frequency, rather than spreading it across the spectrum. These worst case spurs can be eliminated by selecting an initial phase that minimizes the errors or by changing the tuning frequency by a small amount (50 Hz). All spurs can be made to fall below -96 dB with the selection of a proper initial phase or tuning frequency.

3.3.2 Four Stage CIC Filter

The mixer outputs are decimated by a factor of N in a four stage CIC filter, where N is any integer between 8 and 16,384. The programmable decimation allows the chip's usable output bandwidth to range from less than a kilo-Hertz to 1.5 MHz when the input rate (which is equal to the chip's clock rate) is 62.5 MHz. A block diagram of the CIC filter is shown in Figure 7.

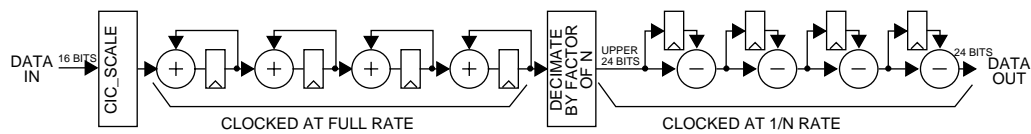

Figure 7. Four Stage CIC Decimate by N Filter

The CIC filter has a gain equal to N^4 which must be compensated for in the "CIC_SCALE" circuit shown in Figure 7. This circuit has a gain equal to $2^{(SCALE+6*BIG_SCALE-56)}$, where SCALE ranges from 0 to 5 and BIG_SCALE ranges from 0 to 7. The gain of the CIC circuit is equal to: $GAIN = N^4 2^{(SCALE + 6 * BIG_SCALE - 56)}$. The user must select values for SCALE and BIG_SCALE such that GAIN is less than one, i.e., SCALE and BIG_SCALE must be selected such that: $(SCALE + 6 * BIG_SCALE) \leq (56 - 4 \log_2 N)$. Overflows due to improper gain settings will go undetected if this relationship is violated. For example, if N is equal to 8, then this restriction means that BIG_SCALE and SCALE

should be less than or equal to 7 and 2 respectively. The BIG_SCALE and SCALE settings are common to all channels.

3.3.3 Coarse Channel Gain

The gain of each channel can be boosted up to 42 dB by shifting the output of the CIC filter up by 0 to 7 bits prior to rounding it to 16 bits. The coarse gain is: $GAIN = 2^{COARSE}$, where COARSE ranges from 0 to 7. Overflows in the coarse gain circuit are saturated to plus or minus full scale. The coarse gain is used to increase the gain of an individual signal after the input bandwidth of the downconverter has been reduced by a factor of N in the CIC filter. If the signal power across the input bandwidth is relatively flat, as is the case in most frequency division multiplexed (FDM) systems, then one would want to boost the signal power out of the CIC filter by a factor of $GAIN = \sqrt{N}$. Each channel can be given its own coarse gain setting. Note that the final gain stage described in Section 3.4 can boost the overall gain by up to 24 more dB.

3.3.4 The Compensating Decimate By Two Filter (CFIR)

The CIC/Coarse gain outputs are filtered by two stages of filtering. The first stage is a 21 tap decimate by 2 filter with two sets of fixed coefficients. The first set of coefficients is used in the normal mode to give a passband which is flat (0.01 dB ripple) over 100% of the final output bandwidth and which has 85 dB of out of band rejection. The filter also compensates for the droop associated with the CIC programmable decimation filter. The filter is symmetric with the following taps:

29, -85, -308, -56, 1068, 1405, -2056, -6009, 1303, 21121, 32703

The narrow set of coefficients are intended for applications that need deeper stop bands or need oversampled outputs. These requirements are common in cellular systems where out of band rejection requirements can exceed 100 dB. The filter coefficients for the narrow mode are:

-98, -679, -2016, -3234, -2537, 850, 6053, 12060, 18230, 23239, 25212

The combined frequency response of the CIC and CFIR filter for both modes is shown below:

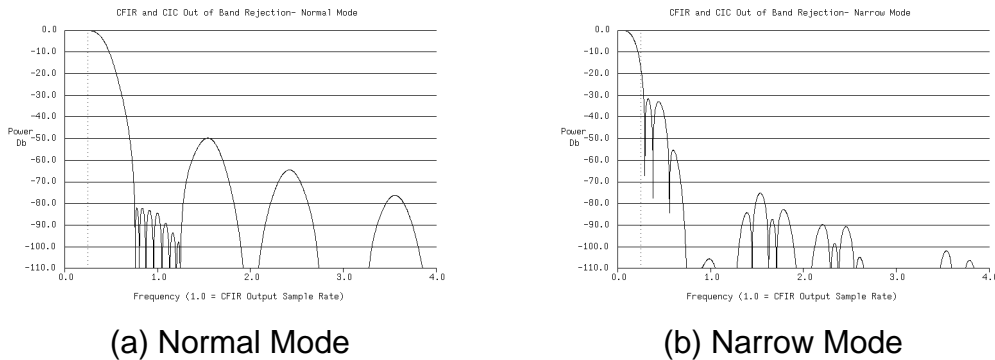

Figure 8. Combined CFIR and CIC Frequency Response

The dashed vertical line in the plots shows the output Nyquist rate for the chip when the PFIR is in the decimate by 2 mode. The narrow mode filter introduces a gain of 1.97 (5.9 dB).

3.3.5 The Programmable Final Filter (PFIR)

The second stage decimate by two or four filter uses either internal ROM based coefficients, or externally downloaded filter coefficients. The internal 80% bandwidth filter has 80 dB of out of band rejection and 0.03 dB peak to peak passband ripple. The internal filter is a 63 tap symmetric filter. The 32 unique coefficients are:

-14, -20, 19, 73, 43, -70, -82, 84, 171, -49, -269, -34, 374, 192, -449,
 -430, 460, 751, -357, -1144, 81, 1581, 443, -2026, -1337, 2437, 2886,
 -2770, -6127, 2987, 20544, 29647

Figure 9(a) shows the overall response for the internal PFIR when the CFIR is in the normal mode. Figure 9(b) shows the overall response when the CFIR is in the narrow mode. Note that the peaks in the stop band at 3.5 times the output sample rate will, after decimation, fold into the transition band from 0.4 to 0.5 of the output sample rate. This out of band power, if necessary, can be filtered out by either using a custom PFIR filter with a narrower passband, or by post-filtering.

An overall response using custom coefficients suitable to meet the stringent GSM Cellular requirements is shown in Figure 9(c). See Sections 7.5 and 7.6 for more details on GSM and DAMPS configurations.

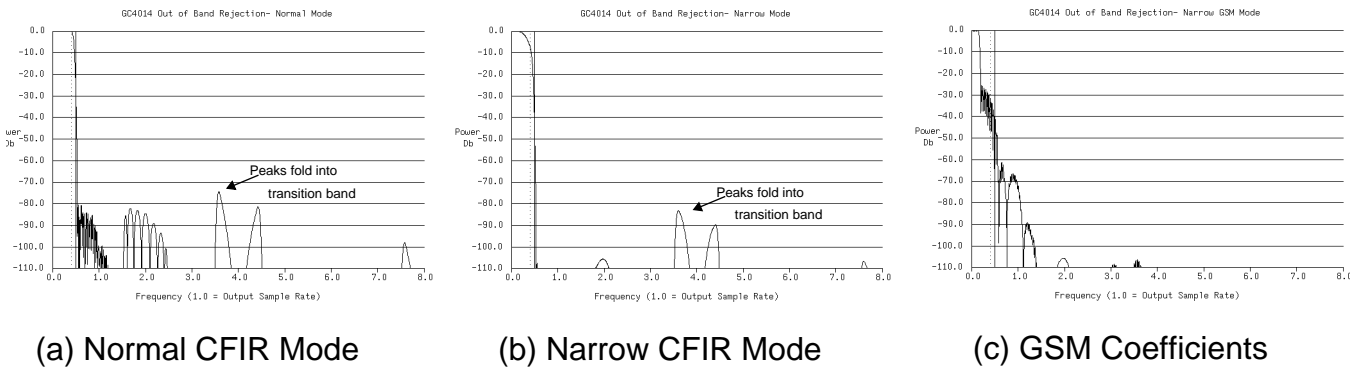

Figure 9. Overall CIC-CFIR-PFIR Response

The externally downloaded coefficients can be used to tailor the spectral response to the user's needs. For example, it can be programmed as a Nyquist (typically a root-raised-cosine) filter for matched filtering digital data. The user downloaded filter coefficients are 16 bit 2's complement numbers. Unity gain will be achieved through the filter if the sum of the 63 coefficients is equal to 65536. If the sum is not 65536, then the PFIR will introduce a gain equal to (sum of coefficients)/65536.

The 63 coefficients are identified as coefficients h_0 through h_{62} , where h_{31} is the center tap. The coefficients are assumed to be symmetric, so only the first 32 coefficients (h_0 through h_{31}) are loaded into the chip. A non-symmetric mode allows the user to download a 32 tap non-symmetric filter as taps h_0 through h_{31} . ERRATA: The non-symmetry mode does not work properly for parts marked with mask code 55532B.

3.3.6 Real Mode

The PFIR will output either complex or real data. Complex data is output at a rate equal to $F_{CK}/(4N)$ or $F_{CK}/(8N)$ in the decimate by 4 mode. If the output samples are real, then the filter translates the output spectrum up by multiplying the filtered data by the complex sequence $+1, -j, -1, +j, \dots$, and then outputting the real part at a rate equal to $F_{CK}/2N$. The real output mode can be used to create double sided signals out of single sideband data. The real outputs are packed into complex words for output. The first sample of a real pair is put into the I-half and the second is put into the Q-half. Note that the decimate by 4 mode is invalid in the real mode.

3.4 FINAL GAIN ADJUSTMENT

The final gain of each channel is adjusted by multiplying each output sample by $G/32$, where G is a 10bit 2's complement gain word. Since G can range between -512 and $+511$, the gain adjustment will range from -16.0 to $+15.98$. Setting G to zero clears the channel. This provides a final gain adjustment range from $-\infty$ to $+24$ dB in approximately 0.28 dB steps. A different gain can be specified for each channel. Note that the overall gain of the chip is also a function of the amount of decimation programmed into the chip (N), the scale circuit setting in the CIC filter, the coarse gain setting, the narrow mode in the CFIR, and the sum of the PFIR coefficients. The overall gain is shown below where the first term in braces is fixed for all four channels and must be less than or equal to unity. The terms in square brackets can be different for each channel. NARROW is "1" in the narrow CFIR mode, "0" otherwise. See Section 7.9 for a discussion on properly setting the chip's gain.

$$GAIN = \{N^4 2^{(SCALE + 6 \times BIG_SCALE - 56)}\} [2^{COARSE}] \{ 1.0 + NARROW \times 0.97 \} \{ \frac{PFIR_SUM}{65536} \} [\frac{G}{32}]$$

3.5 SUMMATION MODES

The chip can be programmed to output the four individual channels, the sum of pairs of channels, or the sum of all four channels. These modes are used to process four real input signals, two complex input signals, or one beamformed signal. When processing two complex input signals, the I inputs are put in channels A and C, and the Q inputs are put in channels B and D. The summation mode then adds channels A and B together and channels C and D together.

Summation is disabled in Sum Mode 0. In Sum Mode 1 the channel A output is replaced by the sum of channels A and B, the channel B output is replaced by the sum of channels C and D, and the channel C and D outputs are left alone. In Sum Mode 2 the channel A output becomes the sum of all four channels and channels B, C and D are left alone. These modes are summarized in the following table:

Table 1: Output Summation Modes

SUM MODE	CHANNEL OUTPUT			
	OUT _A	OUT _B	OUT _C	OUT _D
0	CH _A	CH _B	CH _C	CH _D
1	CH _A + CH _B	CH _C + CH _D	CH _C	CH _D
2	CH _A + CH _B + CH _C + CH _D	CH _B	CH _C	CH _D

3.6 OUTPUT MODES

The channel or summation outputs are accessible either through internal control registers, through bit serial outputs, or through nibble serial (link mode) outputs. Note that the bit serial and link mode outputs start, after power up, in a tri-state condition and must be turned on when the chip is configured.

3.6.1 Internal Control Registers

The internal control registers are loaded by the chip once every output sample period (OSP)¹ and held for the rest of the period. The user is notified that new samples are ready and a new OSP has begun, either through an interrupt signal provided by the chip's "READY" pin (RDY/ACK pin), or through a control register bit.

3.6.2 Serial Outputs

The chip provides a bit serial clock (SCK), a frame strobe (SFS) and four data bit lines (SOUT A,B,C and D) to output the data. A MUX_MODE control specifies whether the four data outputs are transmitted on four separate bit-serial pins, or multiplexed onto two, or just one pin in a TDM format. Separate output pins are not provided for the I and Q halves of complex data. The I and Q outputs are always multiplexed onto the same bit-serial pin. The 16 bit I-component is output first, followed by the Q-component. The "packed mode" allows a complex pair to be treated as a single 32 bit word. The "READY" signal is used to identify the first word of a complex pair or of the TDM formatted output. The TDM modes are summarized in the following table (See Table 1 for a definition of OUT in the summation modes):

Table 2: TDM Modes

MUX MODE	SERIAL OUTPUT			
	A _{OUT}	B _{OUT}	C _{OUT}	D _{OUT}
0	OUT _A	OUT _B	OUT _C	OUT _D
1	OUT _A , OUT _B		OUT _C , OUT _D	
2	OUT _A , OUT _B , OUT _C , OUT _D			

The bit serial outputs use the format shown in Figure 10. Figure 10(a) shows the standard output mode (the PACKED mode bit is low). The chip clocks the frame and data out of the chip on the rising edge of SCK (or falling edge if the SCK_POL bit in the input control register is set). The chip sends the 16 bits (I data first) by setting SFS high (or low if SFS_POL in the input control register is set) for one clock cycle, and then transmitting the data, MSB first, on the next 16 clocks. The I/Q data is transmitted "back to back" as shown in Figure 10(a). If the PACKED control bit is high, then the I and Q components are sent as a single 32 bit word with only one SFS strobe as shown in Figure 10(b). If two or more channels are multiplexed out the same serial pins, then the subsequent I/Q channel

1. Output sample period (OSP) refers to the interval between output samples at the decimated output rate. For example, if the input rate (and clock rate) is 10 MHz and the overall decimation factor is 100 (N=25) the OSP will be 10 microseconds. An OSP starts when a new sample is ready and stops when the next one is ready.

words will be transmitted immediately following the first I/Q pair as shown in Figure 10(c). Figure 10(c) also shows how the RDY signal can be used to identify the I and Q channels in the TDM serial transmission. The bit-serial output rate is programmable as a power-of-2 division of the input clock.

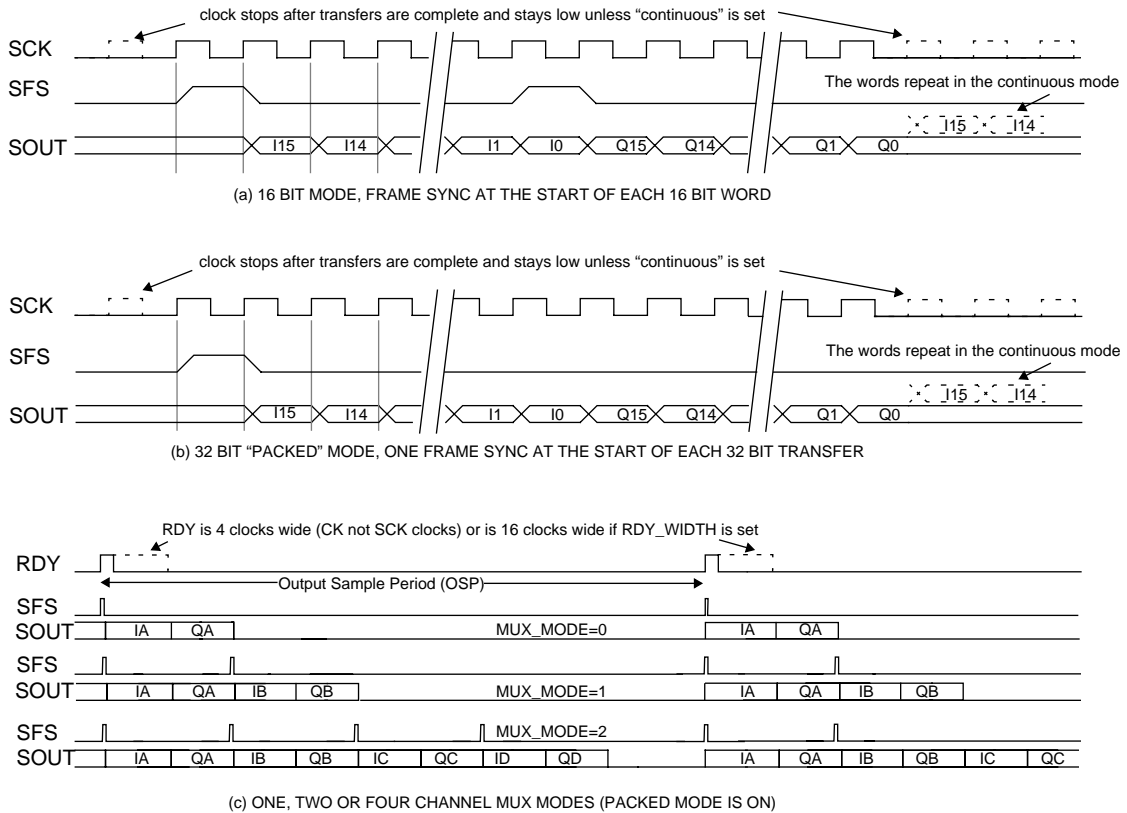

Figure 10. Serial Output Formats

The serial clock (SCK) will normally stop after the last bit transfer of each OSP. The user can force a continuous clock by setting the CONTINUOUS control bit in the output control register. In the continuous mode the data is repeated until the next OSP. This may be useful if the user wants to multiplex the outputs from multiple chips onto the same serial bus. Note: The frame syncs are not intended to be used in the continuous mode. After the proper number of frame syncs have been output as shown in Figure 10, the next frame sync will be missing in the continuous mode. The frame syncs will then repeat every 16 (or 32 in the packed mode) bit clocks. Note also that the number of bit clocks per output frame may not be a rational number, resulting in a truncated bit clock at the end of the OSP.

3.6.3 Link Mode Output

The four serial output pins and the bit clock and frame sync pins can be configured as an ADSP-2106x SHARC DSP chip link port. These pins are in a tri-state condition when the chip powers up. A control bit is set to enable these pins and another control bit is set to enable the link port mode. In the link mode the READY output pin becomes the ACK (acknowledge) input which is used to receive the link port "LACK" signal.

The link port's timing is as follows: The GC4014 checks the state of the ACK pin at the start of an OSP. If ACK is low, the chip does nothing. If ACK is high, then the chip will transmit one, two or four complex words out of the link port. The words are either the channel outputs or the sums of channels depending upon the summation mode settings. The number of outputs transmitted is determined by the MUX_MODE settings. If MUX_MODE is 0, only OUT_A will be transmitted. If MUX_MODE is 1, then OUT_A and OUT_B will be transmitted. If MUX_MODE is 2, then all four will be transmitted. See Table 1 for a definition of OUT in the summation modes.

The data is transmitted in four bit nibbles on the rising edge of the bit clock. The transmission is completed in 8, 16 or 32 clocks to transmit one, two or four complex pairs. If the ACK signal is low at the end of a word (after clocks 8, 16, 24 and 32), then the clock will remain high and the transmission of the next word will be delayed until ACK goes high again. If the ACK signal is low at the start of an OSP, then the transmission will be held off until the next OSP. The clock remains low at the end of the transmission until the next OSP starts. The bit clock rate is programmable as a division of the chip's clock.

3.7 CLOCKING

The chip can be clocked in one of two modes. In the standard mode, the clock rate is equal to the input data rate which can be up to 62.5 MHz. An internal clock doubler doubles the clock rate so that the internal circuitry is clocked at twice the data rate. To use the standard mode the CKMODE pin must be grounded and the internal control register bit EN_DOUBLER must be set high (See Section 5.10).

The alternate clock mode (pin CKMODE is high) accepts a double rate clock on the CK2X pin and bypasses the clock doubler circuit. The EN_DOUBLER control bit should be low. In the alternate mode the user must provide both the standard clock and the double rate clock.

3.8 POWER DOWN MODES

The chip has a power down and keep alive circuit. This circuit contains a slow, nominally 1 KHz, oscillator and a clock-loss detect cell. This circuit is used to detect the loss of clock and provide a slow keep-alive clock to the chip. The circuit is also used to power down the chip by switching from the high speed input clock to the low speed keep-alive clock. The low speed clock rate is slow enough to power down the chip while fast enough to refresh the dynamic nodes within the chip. The user can select whether this circuit is in the automatic clock-loss detect mode, is always on (power down mode), or is disabled (the slow clock never kicks in). The whole chip, or individual down converter channels can be powered down. Using the power down mode for individual channels can save significant power.

3.9 SYNCHRONIZATION

Each GC4014 chip can be synchronized through the use of a sync input signal, an internal one shot sync generator, or a sync counter. Each circuit within the chip, such as the sine/cosine generators or the decimation

control counter can be synchronized to one of these sources. These syncs can also be output from the chip so that multiple chips can be synchronized to the syncs coming from a designated “master” GC4014 chip.

3.10 DATA LATENCY

The latency through the chip, including all pipeline delays and filtering group delays, is shown in the following table (N is the CIC filter's decimation ratio, see Section 3.5, \overline{SI} is the sync input to the chip, \overline{SO} is the sync output from the chip, and the **RDY** signal marks the beginning of each output frame, See Figure 10):

Table 3: Latency

FROM INPUT	TO OUTPUT	LATENCY	UNITS	COMMENT
\overline{SI}	\overline{SO}	3	Clocks	sync in to sync out, Register settings: OUTPUT_SYNC = 1, SO_INT_MODE = 0
\overline{SI}	RDY	$3.5N+9$	Clocks	Sync in to first valid RDY out
IN[0:13] at RDY	OUT (First)	5	Outputs	Data sample input coincident with RDY , to the first output affected by it
IN[0:13] at RDY	OUT (Midpoint)	22	Outputs	-to the closest midpoint output affected by IN
IN[0:13] at RDY	OUT (Last)	37	Outputs	-to the last output affected by IN
IN[0:13] at RDY	OUT (Step Response)	$86N+15$	Clocks	Step function delay, step edge is input coincident with RDY , to the step edge output

The last entry can be used to identify the group delay through the chip for time tagging events which pass through the chip, where the time tag needs to be accurate to fractions of the output sample. Note that the overall decimation in the complex output mode is one sample every $4N$ inputs. This means that the step edge will come out 21 samples plus $(2N+15)$ clocks later. A good time tag algorithm would be to count the number of clock cycles between the tagged input sample and the next **RDY** signal (the number D), and then tag the output sample that comes 21 **RDY** signals later with a time tag which is adjusted by $(D - 2N - 15)$ clocks. To insure that the adjustment is always positive, one would wait 22 **RDY** signals (22 outputs) and tag the sample with an adjustment of $(D + 2N - 15)$ clocks. Note that the output sample to be tagged is the sample that is output between the 22nd **RDY** signal and the next **RDY** signal (see Figure 10).

3.11 DIAGNOSTICS

The chip has an internal ramp generator which can be used in place of the data inputs for diagnostics. An internal checksum circuit generates a checksum of the output data to verify the chip's operation. Section 7.7 gives suggested checksum configurations and their expected checksums.

Besides the internal diagnostics, the chip can support board level testing, an output test configuration which can help initial debug as well as production test is described in Section 7.8.

4.0 PACKAGING

The GC4014 chip comes in a 100 pin thin plastic quad flatpack package

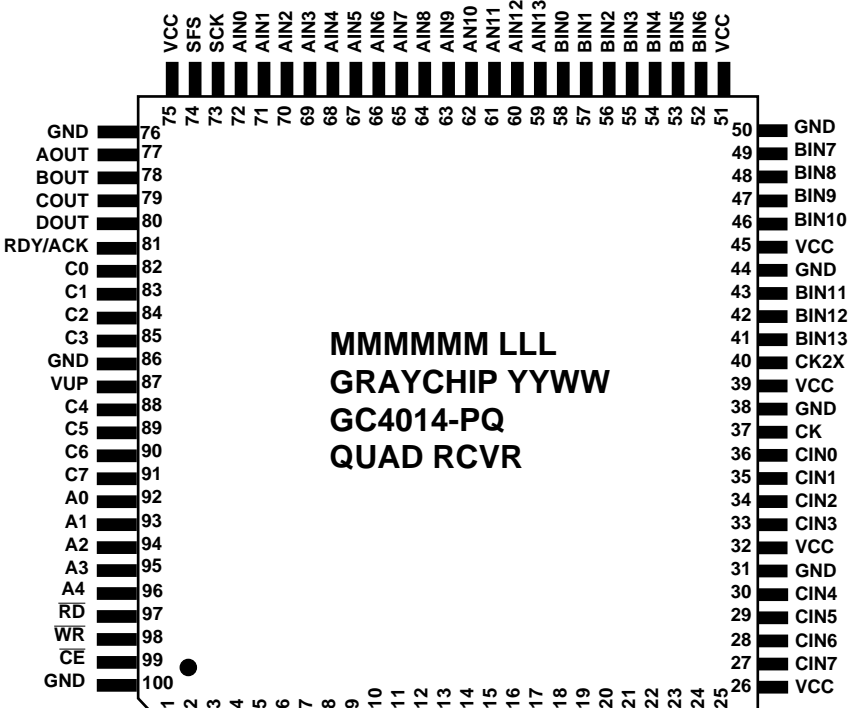
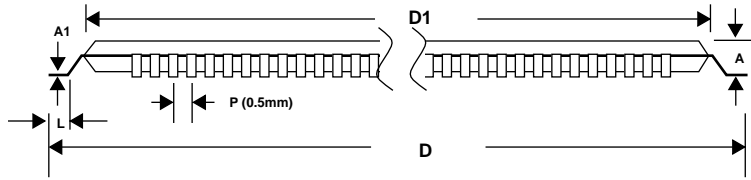
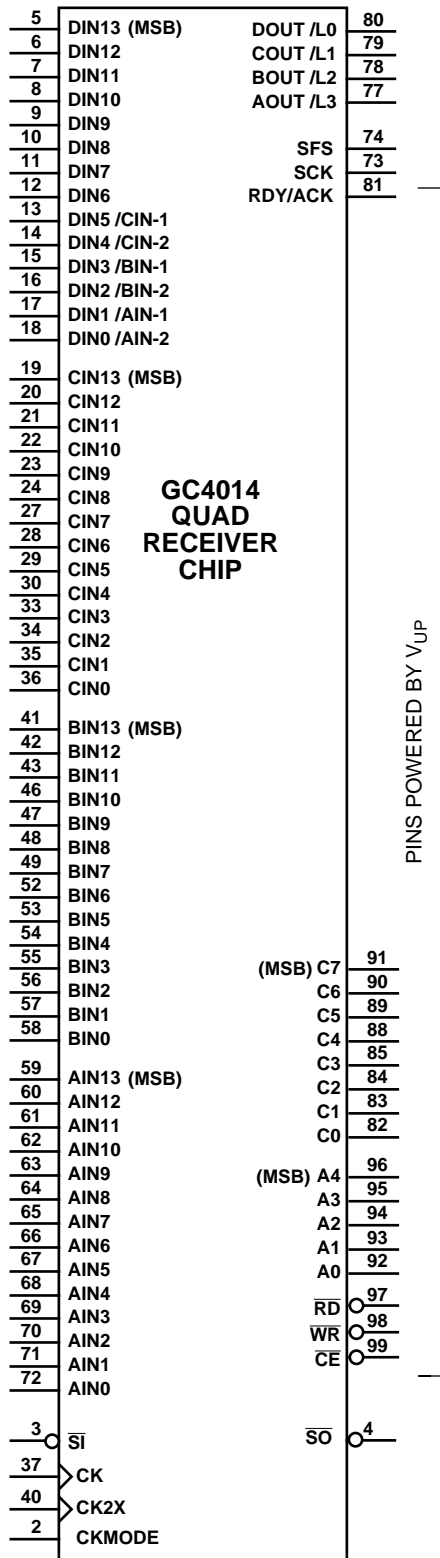

100 PIN THIN QUAD FLAT PACK
GC4014-PQ: PLASTIC PACKAGE
GC4014-CQ: CERAMIC PACKAGE

DIMENSION	PLASTIC	CERAMIC
D (width pin to pin)	16.0 mm (0.630")	17.2 mm (0.677")
D1 (width body)	14.0 mm (0.551")	14.0 mm (0.551")
P (pin pitch)	0.5 mm (0.020")	0.5 mm (0.020")
B (pin width)	0.22 mm (0.009")	0.20 mm (0.008")
L (leg length)	0.60 mm (0.024")	0.70 mm (0.028")
A (height)	1.5 mm (0.059")	3.1 mm (0.122")
A1 (pin thickness)	0.15 mm (0.006")	0.2 mm (0.008")

MMMMM = Mask Code
 LLL = Lot Code
 YYWW = Date Code

VCC PINS: 1, 26, 32, 39, 45, 51, 75
 GND PINS: 25, 31, 38, 44, 50, 76, 86, 100
 VUP PIN: 87

NOTE: 0.01 to 0.1 μ f DECOUPLING CAPACITORS SHOULD BE PLACED AS CLOSE AS POSSIBLE TO EACH SIDE OF THE CHIP

<u>SIGNAL</u>	<u>DESCRIPTION</u>
AIN, BIN, CIN, DIN	INPUT DATA, Active high The 14 bit 2's complement input data for the four channels. The data is clocked into the chip on the rising edge of the clock (CK). The LSBs of DIN are used as the LSBs of AIN , BIN and CIN in the 16 bit input mode (the pins DIN0/AIN-2 , DIN2/BIN-2 and DIN4/CIN-2 are the LSBs of the 16 bit AIN , BIN and CIN inputs).
AOUT, BOUT, COUT, DOUT	BIT SERIAL OUTPUT DATA, Active high The bit serial output data are transmitted on these pins. In the serial mode these are individual outputs, in the link mode these form a four bit nibble (DOUT/L0 is the LSB of the Nibble, AOUT/L3 is the MSB). The output bits are clocked out on the rising edge of SCK (falling edge if SCK_POL=1). These pins are tri-stated at power up and are enabled by the OUTPUT_ENABLE control register bit.
SCK	BIT SERIAL DATA CLOCK, Active high or low The serial data bits are clocked out of the chip by this clock. The active edge of the clock is user programmable. This pin is tri-stated at power up and is enabled by the OUTPUT_ENABLE control register bit.
SFS	BIT SERIAL FRAME STROBE, Active high or low The bit serial word strobe. This strobe delineates the 16 or 32 bit words within the bit serial output streams. This strobe is a pulse at the beginning of each bit serial word. The polarity of this signal is user programmable. This pin is tri-stated at power up and is enabled by the OUTPUT_ENABLE control register bit.
RDY/ACK	READY OR ACKNOWLEDGE FLAG, programmable active high or low The chip asserts this signal in the serial output mode to identify the beginning of an output sample period (OSP). The width in input clock cycles and polarity of this signal are user programmable. This signal is typically used as an interrupt to a DSP chip, but can also be used as a start pulse to dedicated circuitry. In the link mode this pin is an input pin and is tied to the LACK handshake output from an ADSP-2106x SHARC DSP link port. This pin is tri-stated at power up and is enabled in the serial mode by the OUTPUT_ENABLE control register bit.
CK	INPUT CLOCK, Active high The clock input to the chip. The AIN , BIN , CIN , DIN and $\overline{\text{SI}}$ input signals are clocked into the chip on the rising edge of this clock.
CK2X	DOUBLE RATE INPUT CLOCK, Active high The double rate clock input to the chip. Used in the alternate clock mode to clock the chip. This clock must be exactly twice the frequency of the CK clock. Should be grounded in the normal clock mode.
CKMODE	CLOCK MODE, Active high The clock mode control. The chip uses CK2X when this pin is tied high (alternate mode) to clock the internal circuitry. When this signal is grounded (normal mode) the chip doubles the CK clock to use as the internal clock.
$\overline{\text{SI}}$	SYNC IN, Active low The sync input to the chip. All timers, accumulators, and control counters are, or can be, synchronized to $\overline{\text{SI}}$. This sync is clocked into the chip on the rising edge of the input clock (CK).
$\overline{\text{SO}}$	SYNC OUT, Active low This signal is either a delayed version of the input sync $\overline{\text{SI}}$, the sync counter's terminal count (TC), or a one-shot strobe. The $\overline{\text{SO}}$ signal is clocked out of the chip on the rising edge of the input clock (CK).
C[0:7]	CONTROL DATA I/O BUS, Active high This is the 8 bit control data I/O bus. Control register data is loaded into the chip or read from the chip through these pins. The chip will only drive these pins when $\overline{\text{CE}}$ is low and $\overline{\text{RD}}$ is low and WR is high.
A[0:4]	CONTROL ADDRESS BUS, Active high These pins are used to address the control registers within the chip. Each of the control registers within the chip are assigned a unique address. A control register can be written to or read from by setting A[0:4] to the register's address.
$\overline{\text{RD}}$	READ ENABLE, Active low This pin enables the chip to output the contents of the selected register on the C[0:7] pins when $\overline{\text{CE}}$ is also low.
$\overline{\text{WR}}$	WRITE ENABLE, Active low This pin enables the chip to write the value on the C[0:7] pins into the selected register when $\overline{\text{CE}}$ is also low.
$\overline{\text{CE}}$	CHIP ENABLE, Active low This control strobe enables the read or write operation. The contents of the register selected by A[0:4] will be output on C[0:7] when $\overline{\text{RD}}$ is low and $\overline{\text{CE}}$ is low. If $\overline{\text{WR}}$ is low and $\overline{\text{CE}}$ is low, then the selected register will be loaded with the contents of C[0:7] .
Vup	MICROPROCESSOR INTERFACE POWER SUPPLY, Power Supply This pin provides power for the microprocessor interface to allow it to interface to 5 volt logic. Input pins (A[0:4] , $\overline{\text{RD}}$, $\overline{\text{WR}}$, $\overline{\text{CE}}$, C[0:7] , and RDY/ACK) must not be driven above Vup+0.3V . The output pins (C[0:7] , RDY/ACK) will drive a logic one to Vup under no load.

5.0 CONTROL REGISTERS

The chip is configured and controlled through the use of eight bit control registers. These registers are accessed for reading or writing using the control bus pins (\overline{CE} , \overline{RD} , \overline{WR} , **A[0:4]**, and **C[0:7]**) described in the previous section. The register names and their addresses are:

The Mode and Control Registers are addresses 0 to 15

<u>ADDRESS</u>	<u>NAME</u>	<u>ADDRESS</u>	<u>NAME</u>
0	Sync Mode	8	Blank Control
1	Decimation Mode	9	Channel Flush Control
2	Decimation Byte 0	10	Counter Byte 0
3	Decimation Byte 1	11	Counter Byte 1
4	Scale Control	12	Test Mode
5	Channel Gain	13	Page Map
6	Output Format	14	Status
7	Output Mode	15	Checksum

Addresses 16 to 31 are used in sixteen pages as determined by the page select control bits in the page map register. The page assignments are:

<u>PAGE</u>	<u>NAME</u>	<u>PAGE</u>	<u>NAME</u>
0	Channel Outputs	8	Coefficients 0 to 7
1	Keepalive Status	9	Coefficients 8 to 15
2	unused	10	Coefficients 16 to 23
3	unused	11	Coefficients 24 to 31
4	Channel Control A	12	unused
5	Channel Control B	13	unused
6	Channel Control C	14	unused
7	Channel Control D	15	unused

The following sections describe each of these registers. The type of each register bit is either R, W, or R/W indicating whether the bit is read only, write only, or read/write. All bits are active high.

5.1 SYNC MODE REGISTER

The Sync mode control register determines how the circuits within the chip are synchronized. Each circuit which requires synchronization can be configured to be synchronized to the sync input (**SI**), or to the terminal count of the sync counter (**TC**). The sync to each circuit can also be set to be always on or always off. Each circuit is given a two bit sync mode control which is defined as:

Table 4: Sync Modes

MODE	SYNC DESCRIPTION
0	"0" (never asserted)
1	SI
2	TC (or OS, if USE_ONESHOT is set)
3	"1" (always active)

NOTE: the internal syncs are active high. The $\overline{\text{SI}}$ input has been inverted to be the active high sync **SI**.

ADDRESS 0: **Sync Mode, suggested default = 0x65**

BIT	TYPE	NAME	DESCRIPTION
0,1 (LSBs)	R/W	DEC_SYNC	Synchronizes the decimation control counter. The decimation counter controls the filter timing of each channel and the serial timing of the output signals.
2,3	R/W	COUNTER_SYNC	Synchronizes the sync counter. This counter is used to generate the periodic "TC" sync pulses. Mode 2 in Table 4 is always OS.
4,5	R/W	OUTPUT_SYNC	The selected sync is inverted and output on the $\overline{\text{SO}}$ pin.
6	R/W	USE_ONESHOT	The terminal count mode in table 4 is replaced by the one shot pulse (OS) when this bit is set.
7	R/W	ONE_SHOT	The one shot sync pulse (OS) is generated when this bit is set. This bit must be cleared before another one shot pulse can be generated.

If the user wishes to allow the chip to free run, asynchronous to other chips, then the sync settings can be set to zero. If one wishes to synchronize several chips to a single sync source, then the sync mode selections should be set to one. The suggested default is to output the one-shot (USE_ONESHOT = 1, OUTPUT_SYNC=2) and set all other syncs to SI. The user should tie the $\overline{\text{SO}}$ output pin of one GC4014 chip to the $\overline{\text{SI}}$ input pin of all other GC4014 chips in a system in order to cleanly synchronize and initialize one or more GC4014 chips. If there is only a single GC4014 chip, then all sync mode selections can be set to "2" to receive the one-shot directly. A one-shot should be sent after initialization and each time the decimation ratio is changed.

5.2 DECIMATION MODE REGISTER

Registers 1 and 2 control the decimation modes for the chip. These settings are common to all channels

ADDRESS 1: Decimation Mode, *suggested default = 0x80, power up resets to 0.*

<u>BIT</u>	<u>TYPE</u>	<u>NAME</u>	<u>DESCRIPTION</u>
0 LSB	R/W	REAL	Enables the PFIR's real output mode. (See Section 3.3.6). The real outputs are formatted into complex pairs in the real mode. The I-output words contain the even-time real outputs and the Q-outputs contain the odd-time real outputs.
1	R/W	FILTER_SELECT	The user downloaded filter coefficients are used instead of the built in filter coefficients for the second stage FIR filter when this bit is set.
2	R/W	RDY_POL	This control bit inverts the polarity of the RDY output. Normally RDY pulses high when a new sample is ready and an output sample period (OSP) is starting. RDY will pulse low when RDY_POL is high.
3	R/W	RDY_WIDTH	Normally the RDY pin will pulse active for four clock cycles. This control bit forces RDY to be active for 16 clocks.
4	R/W	LINK_MODE	Output the data in the nibble-serial link mode. The RDY/ACK pin becomes an input pin in this mode. NOTE: To use the link mode this bit must be set before the OUTPUT_ENABLE control bit in register 8 is set, otherwise the RDY/ACK pin will be driven as an output, possibly damaging the pin.
5	R/W	SO_INT_MODE	The SO output pin is used as an overflow interrupt pin when this bit is set. If an overflow due to gain settings occurs in any of the channels the SO pin will go low if this bit is set.
6	R/W	NO_SYMMETRY	The second stage decimate by two filter is normally a 63 tap symmetric filter. It becomes a 32 tap non-symmetric filter when this bit is set. ERRATA: The non-symmetry mode does not work properly for parts marked with mask code 55532B, parts with other mask codes work.
7 MSB	R/W	EN_DOUBLER	This bit must be set to enable the clock doubler circuit when the CKMODE pin is low. This bit is ignored when CKMODE pin is tied high.

5.3 CIC DECIMATION REGISTERS

Registers 2, and 3 contain the 14 bit CIC decimation ratio control.

ADDRESS 2: Decimation Byte 0, *suggested default = 0x07*

<u>BIT</u>	<u>TYPE</u>	<u>NAME</u>	<u>DESCRIPTION</u>
0-7	R/W	DEC[0:7]	The LSBs of the decimation control

ADDRESS 3: Decimation Byte 1, *suggested default = 0x00*

<u>BIT</u>	<u>TYPE</u>	<u>NAME</u>	<u>DESCRIPTION</u>
0-5	R/W	DEC[8:13]	The 6 MSBs of the decimation control
6,7	R	zero	These bits are read only zeros.

Where **DEC** is equal to **N-1**. The chip decimates the input data by a factor of 2N for real output data and 4N for complex output data (or 8N if **DEC_BY_4** is set in Register 13), where **N** ranges from 8 to 16384. This provides an decimation range from 32 to 65,536 for complex output signals and 16 to 32,768 for real output signals.

5.4 SCALE CONTROL REGISTER

Register 4 controls the CIC filter gain for the chip. These settings are common to all channels

ADDRESS 4: **CIC Scale, suggested default = 0x71**

BIT	TYPE	NAME	DESCRIPTION
0-2	R/W	SCALE	SCALE ranges from 0 to 5.
3	R/W	unused	
4-6	R/W	BIG_SCALE	BIG_SCALE ranges from 0 to 7.
7	R/W	unused	

The CIC filter has a gain which is equal to N^4 . To remove this gain the CIC inputs are pre-scaled down by $(56-SCALE-6*BIG_SCALE)$ bits before filtering. The overall gain of each channel is equal to:

$$GAIN = \{N^4 \cdot 2^{(SCALE + 6 \times BIG_SCALE - 56)}\} [2^{COARSE}] \{ 1.0 + NARROW \times 0.97 \} \{ \frac{PFIR_SUM}{65536} \} [\frac{G}{32}]$$

where COARSE and G are unique for each channel (See Section 5.17). PFIR_SUM is the sum of the 63 PFIR coefficients if FILTER_SELECT in Register 1 is set, and NARROW is the CFIR narrow mode bit in Register 13. The values of SCALE and BIG_SCALE must be such that the term in braces is less than unity, i.e., $(SCALE + 6 \times BIG_SCALE) \leq (56 - 4\log_2 N)$. Overflows due to improper gain settings will go undetected if this relationship is violated. For example, this restriction means that BIG_SCALE and SCALE should be less than or equal to 7 and 2 respectively for N equal to 8. The BIG_SCALE and SCALE settings are common to all channels. See Section 7.9 for a discussion on how to optimally set the gain of the chip.

5.5 CHANNEL GAIN REGISTER

Register 5 contains the most significant 2 bits of each channel's gain setting G. The least significant bits are stored in each channel's control page (See Section 5.17).

ADDRESS 5: **Channel Gain, suggested default = 0x00**

BIT	TYPE	NAME	DESCRIPTION
0,1	R/W	GA[8:9]	2 MSBs of Channel A's gain.
3,4	R/W	GB[8:9]	2 MSBs of Channel B's gain.
4,5	R/W	GC[8:9]	2 MSBs of Channel C's gain.
6,7	R/W	GD[8:9]	2 MSBs of Channel D's gain.

Since the gain is $G/32$, and these bits are only used if G is greater than 256 (except for negative values), then setting this register to zero still allows the user to add up to 18 dB of gain by just using the 8 LSB's set in the channel control pages. If more than 18 dB is desired, then these control register bits can be used. See Section 7.9 for a discussion on how to optimally set the gain of the chip.

5.6 OUTPUT FORMAT REGISTER

This register controls the output bit serial format.

ADDRESS 6: **Output Format Register**, *suggested default = 0x01*

<u>BIT</u>	<u>TYPE</u>	<u>NAME</u>	<u>DESCRIPTION</u>
0-3 LSB	R/W	RATE[0:3]	The bit serial rate is set at $F_{CK}2^{-RATE}$, where RATE can range from 0 to 10. If RATE=0, the SCK pin will not toggle and the serial rate is equal to the clock rate.
4	R/W	PACKED	Puts the serial outputs into 32 bit transfer mode where each complex pair is packed into 32 bit words. The complex pair is formatted as I word in the upper byte and the Q word in the lower byte. Each word is formatted as MSB first.
5	R/W	CONTINUOUS	The serial clock normally stops when the last bit of each transmission is complete and stays low until the next OSP.
6	R/W	SCK_POL	This bit inverts the polarity of the serial clock. Normally SOUT and SFS change on the rising edge of SCK . They change on the trailing edge when this bit is set.
7 MSB	R/W	SFS_POL	The SFS signal is treated as active low when this bit is set. Otherwise the signal is treated as active high.

5.7 OUTPUT MODE REGISTER

This register controls the output summation, multiplexing and rounding.

ADDRESS 7: **Output Mode Register**, *suggested default = 0x00*

<u>BIT</u>	<u>TYPE</u>	<u>NAME</u>	<u>DESCRIPTION</u>
0,1 LSB	R/W	SUM_MODE	The channel outputs are replaced by the sum of outputs as shown in Table 1 of Section 3.5
2,3	R/W	MUX_MODE	The outputs are multiplexed as described in Section 3.6.2.
4	R/W	RND8	Round into the 8 MSBs of the 16 bit output words.
5	R/W	RND10	Round into the 10 MSBs of the 16 bit output words.
6	R/W	RND12	Round into the 12 MSBs of the 16 bit output words.
7 MSB	R/W	RND14	Round into the 14 MSBs of the 16 bit output words.

Only one round control bit can be set. If none are set the output is 16 bits. Bits below the rounding point are set to zero.

5.8 BLANKING CONTROL REGISTER

This register controls the blanking mode.

ADDRESS 8: **Blank Control Register**, *suggested default = 0x50, power up reset to 0.*

<u>BIT</u>	<u>TYPE</u>	<u>NAME</u>	<u>DESCRIPTION</u>
0-3 LSB	R/W	BLANK_RATE	The number of zeroes to insert between each sample in the blanking mode. Ranges from 0 to 15.
4,5	R/W	BLANK_SYNC	The sync selection from Table 4 for synchronizing the zero stuffing.
6	R/W	OUTPUT_ENABLE	Turns on the serial output pins including SFS and SCK . RDY is also turned on if LINK_MODE is off (See Section 5.2).
7 MSB	R/W	RAM_TEST	Used for factory tests. Should be kept low.

Blanking is turned on for each channel using the channel mode register in each channel's control page.

5.9 CHANNEL FLUSH CONTROL REGISTER

This register controls flushing the four channels. Each channel is flushed when the selected sync occurs. The sync is selected according to Table 4 in Section 5.1.

ADDRESS 9: Channel Flush Register, *suggested default = 0x55*

<u>BIT</u>	<u>TYPE</u>	<u>NAME</u>	<u>DESCRIPTION</u>
0,1 LSB	R/W	FLUSH_A[0:1]	The flush sync for channel A.
2,3	R/W	FLUSH_B[0:1]	The flush sync for channel B.
4,5	R/W	FLUSH_C[0:1]	The flush sync for channel C.
6,7 MSB	R/W	FLUSH_D[0:1]	The flush sync for channel D.

Each channel should be flushed when the chip is being initialized or when the decimation control is changed. The flush lasts for 8N clocks after the sync occurs. The channel flush syncs will normally be left in a “never” mode. If a channel is unused, then the user should leave the channel in the “always” flush mode which will clear the datapath, clear the channel’s output, and lower its power consumption. During diagnostics the channels will need to be flushed at the beginning of each sync cycle.

The user may wish to flush a channel when a new frequency is selected in order to purge the datapath of the last signal.

5.10 COUNTER MODE REGISTERS

Registers 10, and 11 set the counter’s cycle period.

ADDRESS 10: Counter Byte 0, *suggested default = 0xff*

<u>BIT</u>	<u>TYPE</u>	<u>NAME</u>	<u>DESCRIPTION</u>
0-7	R/W	CNT[0:7]	The LSBs of the counter cycle period

ADDRESS 11: Counter Byte 1, *suggested default = 0xff*

<u>BIT</u>	<u>TYPE</u>	<u>NAME</u>	<u>DESCRIPTION</u>
0-7	R/W	CNT[8:15]	The 8 MSBs of the counter cycle period

The chip’s internal sync counter counts in cycles of $128(\mathbf{CNT}+1)$ clocks. A terminal count signal (TC) is output at the end of each cycle. The counter can be synchronized to an external sync as specified in the Sync mode Register (See Section 5.1). If **CNT** is set so that $128(\mathbf{CNT}+1)$ is a multiple of twice the decimation ratio (i.e., a multiple of 16N), then the terminal count of this counter can be output on the $\overline{\mathbf{SO}}$ pin and used to periodically synchronize multiple GC4014 chips.

5.11 TEST MODE REGISTER

Register 12 controls the test and diagnostic features of the chip.

ADDRESS 12: Test Mode Register, suggested default = 0x08, power up reset to 0.

<u>BIT</u>	<u>TYPE</u>	<u>NAME</u>	<u>DESCRIPTION</u>										
0,1 LSB	R/W	DIAG_SOURCE	This two bit field selects the diagnostic input source used when the DIAG bit in each channel's control register is set (See Section 5.17). DIAG_SOURCE = 0 selects the 14 LSB's of the counter (see Section 5.10) as a diagnostic ramp. DIAG_SOURCE=1 is a zero input, DIAG_SOURCE=2 is unused, DIAG_SOURCE= 3 gives a 0x4000 constant input.										
2,3	R/W	DIAG_SYNC	The Checksum generator is strobed by this sync. See Table 4 for the possible sync selections.										
4	R/W	COUNT_TEST	Used during factory tests. Should be cleared during normal operation.										
5	R/W	PD_CLOCK_OFF	Turns off the clock in the power down mode.										
6,7	R/W	POWER_DOWN	This two bit field controls the power down and keep alive circuit as follows: <table border="0" style="margin-left: 20px;"> <tr> <td>POWER_DOWN</td> <td>MODE</td> </tr> <tr> <td>0</td> <td>Clock loss detect mode</td> </tr> <tr> <td>1</td> <td>Power down mode</td> </tr> <tr> <td>2</td> <td>Disabled</td> </tr> <tr> <td>3</td> <td>Test</td> </tr> </table> The power_down mode defaults to 0 (clock loss detect mode) upon power up.	POWER_DOWN	MODE	0	Clock loss detect mode	1	Power down mode	2	Disabled	3	Test
POWER_DOWN	MODE												
0	Clock loss detect mode												
1	Power down mode												
2	Disabled												
3	Test												

5.12 PAGE MAP REGISTER

This register selects which page is been accessed by addresses 16 through 31. This register also contains several miscellaneous control bits.

ADDRESS 13: Page Map Register

<u>BIT</u>	<u>TYPE</u>	<u>NAME</u>	<u>DESCRIPTION</u>
0-3 LSBs	R/W	PAGE	The page selection. PAGE=0 selects the channel output data page, PAGE=1 selects the status page, page=4,5,6 and 7 select the channel control pages, pages 8,9,10 and 11 select the PFIR coefficient pages.
4	R/W	NARROW	Selects the narrow mode CFIR coefficients.
5	R/W	DEC_BY_4	Enables the decimate by 4 mode of the PFIR.
6	R/W	16_BIT_INPUT	Enables the 16 bit input mode. DIN[6-13] are unused. DIN[0,1], DIN[2,3], and DIN[4,5] become two additional LSB's for AIN, BIN, and CIN respectively.
7 MSB	R/W	MSB_POL	Invert the input MSB polarity. This will convert an offset binary formatted input to 2's complement format.

5.13 STATUS CONTROL REGISTER

This register contains miscellaneous control and status information.

ADDRESS 14: **Status Control Register**, *suggested default = 0x00*

BIT	TYPE	NAME	DESCRIPTION
0 LSB	R/W	READY	The user sets this bit after reading the output registers. The chip clears this bit when new values have been loaded and it is time to read them.
1	R/W	MISSED	The chip sets this bit if the user has not set the READY bit before the chip loads the output registers. This bit high indicates that an error has occurred.
2	R/W	unused	
3	R/W	GAIN_OVERFLOW	Indicates an overflow in the final gain circuit.
4	R/W	OVERFLOW_A	Indicates overflow in channel A's coarse gain.
5	R/W	OVERFLOW_B	Indicates overflow in channel B's coarse gain.
6	R/W	OVERFLOW_C	Indicates overflow in channel C's coarse gain.
7 MSB	R/W	OVERFLOW_D	Indicates overflow in channel D's coarse gain.

The READY bit is used to tell an external processor when new output samples are ready to be read. If desired, the **RDY** pin can be used as an interrupt to the external processor (See Section 5.2) to tell the processor when to read new samples. The user does not need to set the READY bit if **RDY** is used. If READY is not set, however, the MISSED flag will not be valid.

The overflow bits are set when an overflow occurs and stays set until the user clears them. If the **SO_INT_MODE** bit in control register 1 is set, then the $\overline{\text{SO}}$ pin will go low if OVERFLOW_A, OVERFLOW_B, OVERFLOW_C, or OVERFLOW_D go active. GAIN_OVERFLOW will not cause $\overline{\text{SO}}$ to go low. GAIN_OVERFLOW is set if the final gain circuit detects an overflow in any channel (or sum of channels if SUM_MODE is active).

5.14 CHECKSUM REGISTER

The checksum register is a read only register which contains the checksum of the output data. The checksum is stored in the checksum register and then starts over again each time the DIAG_SYNC (See Section 5.11) occurs. This is a read only register.

ADDRESS 15: **Checksum Register**

BIT	TYPE	NAME	DESCRIPTION
0-7	R	CHECKSUM[0:7]	The checksum.

5.15 CHANNEL OUTPUT PAGE (PAGE = 0)

Addresses 16 through 31 are used to read output values. The outputs are 16 bit two's complement numbers which are read as two 8 bit bytes, the lower address contains the lower byte. See Table 1 for the output value definitions when SUM_MODE is used. The address assignments are:

<u>ADDRESSES</u>	<u>NAME</u>	<u>ADDRESSES</u>	<u>NAME</u>
16,17	A _{OUT} , I-half	24,25	C _{OUT} , I-half
18,19	A _{OUT} , Q-half	26,27	C _{OUT} ,Q-half
20,21	B _{OUT} , I-half	28,29	D _{OUT} , I-half
22,23	B _{OUT} ,Q-half	30,31	D _{OUT} ,Q-half

These are all read only registers.

5.16 KEEPALIVE STATUS PAGE (PAGE = 1)

ADDRESS 16: Clock Status

<u>BIT</u>	<u>TYPE</u>	<u>NAME</u>	<u>DESCRIPTION</u>
0	R	KACK	This bit monitors the keepalive clock.
1	R	KA_MODE	This bit monitors the keepalive mode.
2-7	-	unused	

These bits are used for factory test purposes only.

ADDRESS 17: Mask Revision

<u>BIT</u>	<u>TYPE</u>	<u>NAME</u>	<u>DESCRIPTION</u>
0-7	R	REVISION	Mask revision number.

This address can be used to determine the mask revision number for the GC4014. The mask revision numbers are shown in Table 5 below (the mask codes are printed on the GC4014 package).

Table 5: Mask Revisions

Mask Revision Number (Address 17)	Release Date	Mask Code on Package	Description
0	October 1997	55532B	Original
0	January 1998	55532C	Corrected problems with non-symmetry mode, did not change mask revision number in address 17.

5.17 CHANNEL CONTROL PAGES (PAGES 4, 5, 6, 7)

Pages 4, 5, 6 and 7 contain the frequency, phase, gain and control settings for the four channels. To configure channels A, B, C and D use pages 4, 5, 6 and 7 respectfully. All registers are read/write.

ADDRESSES 16, 17, 18, 19: Frequency

<u>ADDRESS</u>	<u>NAME</u>	<u>DESCRIPTION</u>
16	FREQ[0:7]	Byte 0 (LSBs) of FREQ
17	FREQ[8:15]	Byte 1 of FREQ
18	FREQ[16:23]	Byte 2 of FREQ
19	FREQ[24:31]	Byte 3 (MSBs) of FREQ

The 32 bit frequency control word is defined as:

$$FREQ = 2^{32}F/F_{CK}$$

where F is the desired tuning frequency and F_{CK} is the chip's clock rate (not the CK2X rate). Use positive frequency values to downconvert signals. Use negative frequency values to invert the signal's spectrum. The 32 bit 2's complement frequency words are entered as four bytes, the least significant byte in the lowest address, the most significant in the highest address.

ADDRESSES 20, 21: Phase

<u>ADDRESS</u>	<u>NAME</u>	<u>DESCRIPTION</u>
20	PHASE[0:7]	Byte 0 (LSBs) of PHASE
21	PHASE[8:15]	Byte 1 (MSBs) of PHASE

The 16 bit phase offset is defined as:

$$PHASE = 2^{16}P/2\pi$$

where P is the desired phase in radian from 0 to 2π .

ADDRESS 22: Gain, suggested default = 0x80

<u>ADDRESS</u>	<u>NAME</u>	<u>DESCRIPTION</u>
22	G[0:7]	Byte 0 (LSBs) of G

The upper two bits of G are stored in control register 5. Note that G is only part of the chip's gain and should be used in conjunction with SCALE, BIG_SCALE and COARSE. See Sections 5.4 and 5.5 for details. See Section 7.9 for a discussion on how to optimally set the gain of the chip.

ADDRESS 23: Channel Control, suggested default = 0x0, power up reset to 0.

<u>BIT</u>	<u>TYPE</u>	<u>NAME</u>	<u>DESCRIPTION</u>
0,1 LSB	R/W	INPUT	This two bit field selects which chip input should be used by the channel. INPUT = 0,1,2 and 3 correspond to inputs A, B, C and D.
2	R/W	DIAG	Use the diagnostic source as the channel input. See Address 12 (Section 5.11).
3	R/W	BLANK	Turn on blanking for this channel. See address 8, Section 5.8
4-6	R/W	COARSE	The COARSE gain setting used for this channel. See Sections 5.4 and 5.5 for details.
7 MSB	R/W	POWER_DOWN	Used to force the channel into the power down state.

ADDRESS 24: Channel Sync Modes, suggested default = 0x5f

<u>BIT</u>	<u>TYPE</u>	<u>NAME</u>	<u>DESCRIPTION</u>
0,1 LSB	R/W	FREQ_SYNC	The new frequency setting takes affect on this sync.
2,3	R/W	PHASE_SYNC	The new phase offset takes affect on this sync
4,5	R/W	NCO_SYNC	The NCO is initialized to the phase setting by this sync
6,7 MSB	R/W	DITHER_SYNC	The dither circuit is initialized by this sync to zero.

These syncs use the selections shown in Table 4.

The NCO_SYNC is usually set to be always off, unless the user wants to coherently control the phases of multiple channels.

The FREQ_SYNC and PHASE_SYNC are typically set to be always on so that frequency and phase settings will take effect immediately as they are written into their control registers.

The DITHER_SYNC is used to turn on or off the dithering of the NCO phase. To turn off dithering set the DITHER_SYNC to be always on so that it remains initialized to zero. To turn dithering on set the sync to be always off.

During diagnostics the NCO_SYNC and DITHER_SYNC should be set to "TC".

5.18 COEFFICIENT STORAGE PAGES (PAGES 8, 9, 10 and 11)

Addresses 16 to 31 are used to download the 32 user programmable filter coefficients when PAGE is set to 8, 9, 10 and 11. Page 8 is for coefficients 0 through 7, page 9 is for coefficients 8 through 15, page 10 is for coefficients 16 through 23, and page 11 is for coefficients 24 through 31, where coefficient 0 is the first coefficient and coefficient 31 is the middle coefficient of the filter's impulse response. The 16 bit 2's complement coefficients are stored in two bytes, least significant byte first, for example, the LSBs of coefficient 0 are stored in address 16 and the MSBs in address 17.

TO LOAD A COEFFICIENT THE USER MUST WRITE THE LSBYTE FIRST FOLLOWED BY THE MSBYTE. Unknown values will be written into the LSBs if the MSB is written first. The coefficient registers are write only.

6.0 SPECIFICATIONS

6.1 ABSOLUTE MAXIMUM RATINGS

Table 6: Absolute Maximum Ratings

PARAMETER	SYMBOL	MIN	MAX	UNITS	NOTES
DC Supply Voltage	V_{CC}	-0.3	4.1	V	
Control I/O, CKMODE and RDY/ACK Supply Voltage	V_{UP}	-0.3	6.0	V	
Input voltage (undershoot and overshoot)	V_{IN}	-0.5	$V_{CC}+0.5$	V	1
Storage Temperature	T_{STG}	-65	150	°C	
Lead Soldering Temperature (10 seconds)			300	°C	

Notes:

1. MAX is $V_{UP}+0.5$ for the Control I/O and ACK pins.

6.2 RECOMMENDED OPERATING CONDITIONS

Table 7: Recommended Operating Conditions

PARAMETER	SYMBOL	MIN	MAX	UNITS	NOTES
DC Supply Voltage	V_{CC}	3.1	3.5	V	1
Control I/O, CKMODE and RDY/ACK Supply Voltage	V_{UP}	V_{CC}	5.5	V	
Temperature Ambient, no air flow	T_A	-40	+85	°C	2
Junction Temperature	T_J		125	°C	2

1. DC and AC specifications are tested for this range. The GC4014 will operate at derated specifications for lower supply voltages.

2. Thermal management may be required for full rate operation, See Table 8 below

6.3 THERMAL CHARACTERISTICS

Table 8: Thermal Data

THERMAL CONDUCTIVITY	SYMBOL	GC4014-CQ		GC4014-PQ		UNITS
		0.5 Watt	1 Watt	0.5 Watt	1 Watt	
Theta Junction to Ambient	θ_{ja}	54	37	40	32	°C/W
Theta Junction to Case	θ_{jc}	17	15	13	11	°C/W

Note: Air flow will reduce θ_{ja} and is highly recommended.

6.4 DC CHARACTERISTICS

All parameters are industrial temperature range of -40 to 85 °C ambient unless noted.:

Table 9: DC Operating Conditions

PARAMETER	SYMBOL	V _{CC} = 3.1 to 3.5V		UNITS	NOTES
		MIN	MAX		
Voltage input low	V _{IL}		0.8	V	2
Voltage input high, AIN,BIN,CIN,DIN, \bar{S} I,C	V _{IH}	2.1		V	2,3
Voltage input high CK, CK2X	V _{IH}	2.4		V	2
Input current (V _{IN} = 0V)	I _{IN}	Typical +/- 20		uA	2
Voltage output low (I _{OL} = 4mA)	V _{OL}		0.5	V	2
Voltage output high (I _{OH} = -4mA)	V _{OH}	2.4	3.3	V	2,4
Data input capacitance (All inputs except CK)	C _{IN}	Typical 4		pF	1
Clock input capacitance (CK input)	C _{CK}	Typical 10		pF	1

Notes:

1. Controlled by design and process and not directly tested. Verified on initial parts evaluation.
2. Each part is tested at 85°C for the given specification.
3. For V_{UP}=5V, V_{IH}=2.5V for the Control I/O, CKMODE and ACK pins.
4. For V_{UP}=5V, V_{OH}=2.8V (MIN) and V_{OH}=5V (MAX) for the Control I/O and RDY pins.

6.5 AC CHARACTERISTICS

Table 10: AC Characteristics (-40 TO +85°C Ambient, unless noted)

PARAMETER	SYMBOL	3.1V to 3.5V		UNITS	NOTES
		MIN	MAX		
Clock Frequency	F _{CK}	Note 5	64	MHz	2, 3
Clock low period (Below V _{IL})	t _{CKL}	6		ns	2
Clock high period (Above V _{IH})	t _{CKH}	6		ns	2
Clock rise and fall times (V _{IL} to V _{IH})	t _{RF}		2	ns	1
Input setup before CK goes high (AIN , BIN , CIN , DIN , or SI)	t _{SU}	2		ns	2
Input hold time after CK goes high	t _{HD}	2		ns	2
Data output delay from rising edge of CK . (AOUT , BOUT , COU , DOU , SFS , SCK , RDY , or S\bar{O})	t _{DLY}	2 Note 1	15 Note 2	ns	4
Control Setup before both CE , WR or RD go low (See Figure 2.0)	t _{CSU}	3		ns	2, 8
Control hold after CE , WR or RD go high (See Figure 2.0)	t _{CHD}	3		ns	2, 8
Control strobe (CE or WR) pulse width (Write operation, See Figure 2.0)	t _{CSPW}	20		ns	2, 8
Control output delay CE and RD low to C (Read Operation, See Figure 2.0)	t _{CDLY}		30	ns	2, 6, 8
Control tristate delay after CE and RD go high (See Figure 2.0)	t _{CZ}		10	ns	1
Quiescent supply current (V _{IN} =0 or V _{CC} , F _{CK} = 1KHz or POWER_DOWN=1)	I _{CCQ}		7	mA	1
Supply current (F _{CK} =64MHz, N=8)	I _{CC}		400	mA	2, 7

Notes:

1. Typical and not directly tested. Verified on initial part evaluation.
2. Each part is tested at 85 deg C for the given specification.
3. The chip may not operate properly at clock frequencies below MIN and above MAX.
4. Capacitive output load is 20pf. Delays are measured from the rising edge of the clock to the output level rising above V_{IH} or Falling below V_{IL}.
5. The minimum clock rate must satisfy F_{CK}/(4N) > 1KHz.
6. Capacitive output load is 80pf.
7. Current changes linearly with voltage and clock speed: $I_{CC} (MAX) = \left(\frac{V_{CC}}{3.3}\right)\left(\frac{F_{CK}}{50M}\right)\left[31 + A\left(29 + \frac{320}{N}\right)\right]mA$
 where A is the number of active channels (0 to 4) and N is the CIC decimation ratio.
8. See timing diagram in Figure 2 and description in Section 3.1.

7.0 APPLICATION NOTES

7.1 POWER AND GROUND CONNECTIONS

The GC4014 chip is a very high performance chip which requires solid power and ground connections to avoid noise on the V_{CC} and GND pins. If possible the GC4014 chip should be mounted on a circuit board with dedicated power and ground planes and with at least two decoupling capacitors (0.01 and 0.1 μf) adjacent to each GC4014 chip. If dedicated power and ground planes are not possible, then the user should place decoupling capacitors adjacent to each V_{CC} and GND pair.

IMPORTANT

The GC4014 chip may not operate properly if these power and ground guidelines are violated.

7.2 STATIC SENSITIVE DEVICE

The GC4014 chip is fabricated in a high performance CMOS process which is sensitive to the high voltage transients caused by static electricity. These parts can be permanently damaged by static electricity and should only be handled in static free environments.

7.3 SYNCHRONIZING MULTIPLE GC4014 CHIPS

A system containing two or more GC4014 chips will need to be synchronized if coherent operation is desired. To synchronize multiple GC4014 chips connect all of the sync input pins together so they can be driven by a common sync strobe. The common sync strobe can be from an external source, or can be the sync output from one of the chips. If the sync output from one of the chips is used, then the user can choose to output a one shot sync pulse from that chip, or the terminal count from the chip's sync counter. If the terminal count is used, then the sync cycle must be a multiple of 8N and the FLUSH (Address 9), NCO_SYNC and DITHER_SYNC (Address 24 of each channel page) syncs must be set to "never" (see Table 4) after initial synchronization.

7.4 THERMAL MANAGEMENT

The junction temperature must be kept below 125 °C for reliable operation. The chip's power dissipation should be calculated using the equation for supply current in Section 6.5 and then the chip's junction temperature can be calculated using the package's thermal conductivity shown in Section 6.3. At full rate operation ($F_{CK}=62.5$) the power is 1.3 Watts and the junction to ambient rise is 32 degrees per Watt for the plastic package. This represents a rise of 42 degrees over ambient. This means that under these conditions the ambient temperature has to be less than 83 °C. Air flow will decrease the thermal resistance by 10% to 40%, allowing ambient temperatures between 87 °C and 100 °C. Increasing the decimation ratio (N) or decreasing the number of active channels (A) will also allow a higher ambient temperature.

7.5 GSM APPLICATION

The chip meets the stringent GSM out of band rejection requirements by using the narrow CFIR mode. The overall response using the narrow CFIR mode and a programmable PFIR filter coefficient set targeted towards GSM is shown in Figure 11, along with GSM's out of band rejection mask. In band ripple is 0.2 dB (peak to peak).

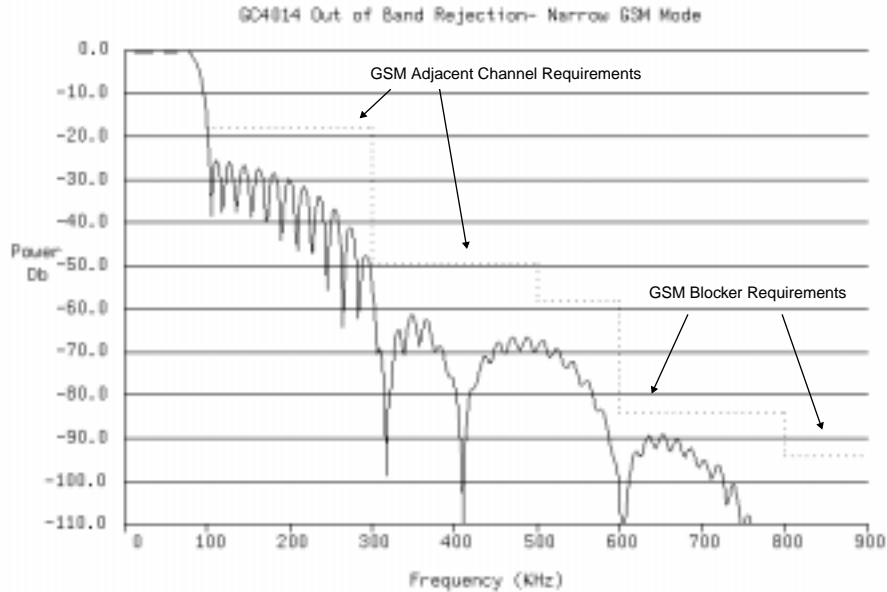

Figure 11. Overall Frequency Response for GSM

This response assumes the input sample rate is equal to $8 \cdot N \cdot B$, where N is the decimation in the CIC filter (See Section 5.3) and B is the GSM bit rate (270.833 KHz). The data is output as two complex samples per bit (541.667 KHz) when the PFIR is in the decimate by 2 mode ($DEC_BY_4 = 0$ in register 13), or is output as one sample per bit (270.833 KHz) when the PFIR is in the decimate by 4 mode ($DEC_BY_4=1$).

The programmable PFIR coefficients for the GSM mode are:

```
1007, -1853, 79, 1807, 1633, 423, 265, 175, -527, -1331, -1454, -1087,
-721, -149, 1008, 1985, 2164, 2005, 1483, 61, -1756, -3134, -3953,
-4016, -2714, 134, 4003, 8361, 12934, 17009, 19565, 20353
```

The suggested GSM control register settings for the chip with an input sample rate of 54.166 MHz (N=25) is shown in Table 12 (other input rates can be used up to 62.5 MHz, 54.166 is used as an example):

Table 11: GSM Configuration

Control Registers		Channel pages 4,5,6,7		Coefficient Pages			
Address	Data	Address	Data	Page 8	Page 9	Page 10	Page 11
00 (HEX)	65 (HEX) ¹	10 (HEX)	FREQ[0:7]	EF	F1	74	66
01	80->82 ²	11	FREQ[8:15]	03	FD	08	F5
02	19	12	FREQ[16:23]	C3	CD	D5	86
03	00	13	FREQ[24:31]	F8	FA	07	00
04	60	14	00 (HEX)	4F	52	CB	A3
05	00	15	00	00	FA	05	0F
06	11	16	2E	0F	C1	3D	A9
07	00	17	00	07	FB	00	20
08	50	18	5F	61	2F	24	86
09	55	19		06	FD	F9	32
0A	FF	1A		A7	6B	C2	71
0B	FF	1B		01	FF	F3	42
0C	08	1C		09	F0	8F	6D
0D	1P ³	1D		01	03	F0	4C
0E	00	1E		AF	C1	50	81
0F	read only	1F		00	07	F0	4F

1. Initialize to 65 while configuring the chip(s), then set to E5, then back to 65 to fire off the one-shot sync. This assumes that $\overline{S\bar{O}}$ is tied to $\overline{S\bar{I}}$

2. Initialize to 80, then set to 82 after external coefficients are loaded.

3. "P" is the page number. The upper nibble should stay at "1".

The variables SCALE, BIG_SCALE (address 4) and G (address 16_{HEX} of pages 4,5,6,and 7) are set as follows. The values of SCALE and BIG_SCALE must be set to satisfy: $(SCALE + 6 \times BIG_SCALE) \leq (56 - 4\log_2 N)$. N is 25, so $(4\log_2 N)$ is 37.14. This means $(SCALE + 6 \times BIG_SCALE) \leq 37$, which is satisfied by setting SCALE=1 and BIG_SCALE=6. SCALE, however, needs to be decreased to 0 to prevent overflow in the CFIR, which has a gain of 1.97. The overall gain is set using "G" according to:

$$GAIN = \{25^4 2^{(36-56)}\} \{2^{COARSE}\} \{1.97\} \left\{ \frac{PFIR_SUM}{65536} \right\} \left[\frac{G}{32} \right] = 0.0438G$$

Where COARSE is 0 and PFIR_SUM is 125151. The optimal setting of GAIN is 2.0 in order to compensate for the loss in the tuning process (See Section 7.9). A value of G=46 (2E_{HEX}) will give a gain of 2.015.

The output serial format is set in address 6 to have a bit rate of one half the chip's clock rate and to be used in the packed mode. The user will need to configure the output format as is necessary for the application.

7.6 DAMPS APPLICATION

The chip meets the DAMPS out of band rejection requirements by using the narrow CFIR mode. The overall response using the narrow CFIR mode and a programmable PFIR filter coefficient set targeted towards DAMPS is shown in Figure 12, along with the out of band rejection mask for DAMPS. The in-band response matches the desired root-raised-cosine receive filter shape to within 0.1 dB.

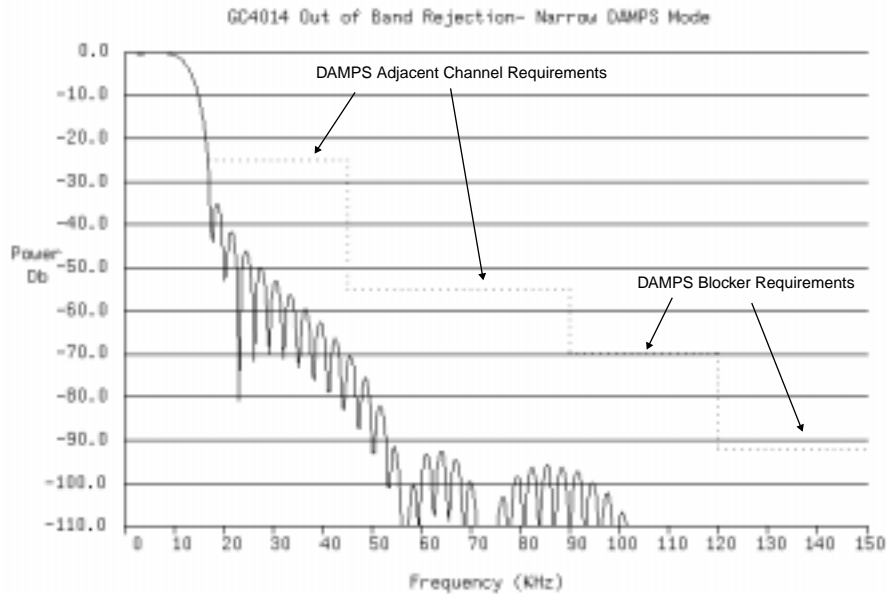

Figure 12. Overall Frequency Response for DAMPS

This response assumes the input sample rate is equal to $16 \cdot N \cdot B$, where N is the decimation in the CIC filter (See Section 5.3) and B is the DAMPS symbol (baud) rate (24.3 KHz). The data is output as four complex samples per symbol (97.2 KHz) when the PFIR is in the decimate by 2 mode ($DEC_BY_4 = 0$ in register 13), or is output as two samples per symbol (24.3 KHz) when the PFIR is in the decimate by 4 mode ($DEC_BY_4=1$).

The programmable PFIR coefficients for the DAMPS mode are:

```
264, 398, 413, 286, 34, -286, -584, -761, -729, -442, 85, 766, 1451,
1954, 2086, 1708, 768, -660, -2371, -4041, -5269, -5640, -4801, -2532,
1194, 6185, 12037, 18172, 23923, 28618, 31691, 32759
```

The suggested DAMPS control register settings for the chip with an input sample rate of 49.7664 MHz (N=128) is shown in the following table (other input rates can be used up to 62.5 MHz, 49.7664 is used as an example):

Table 12: DAMPS Configuration

Control Registers		Channel pages 4,5,6,7		Coefficient Pages			
Address	Data	Address	Data	Page 8	Page 9	Page 10	Page 11
00 (HEX)	65 (HEX) ¹	10 (HEX)	FREQ[0:7]	08	27	00	AA
01	80->82 ²	11	FREQ[8:15]	01	FD	03	04
02	7F	12	FREQ[16:23]	8E	46	6C	29
03	00	13	FREQ[24:31]	01	FE	FD	18
04	43	14	00 (HEX)	9D	55	BD	05
05	00	15	00	01	00	F6	2F
06	11	16	12	1E	FE	37	FC
07	00	17	00	01	02	F0	46
08	50	18	5F	22	AB	6B	73
09	55	19		00	05	EB	5D
0A	FF	1A		E2	A2	F8	CA
0B	FF	1B		FE	07	E9	6F
0C	08	1C		B8	26	3F	CB
0D	1P ³	1D		FD	08	ED	7B
0E	00	1E		07	AC	1C	F7
0F	read only	1F		FD	06	F6	7F

1. Initialize to 65 while configuring the chip(s), then set to E5, then back to 65 to fire off the one-shot sync. This assumes that $\overline{S0}$ is tied to $\overline{S1}$

2. Initialize to 80, then set to 82 after external coefficients are loaded.

3. "P" is the page number. The upper nibble should stay at "1".

The variables SCALE, BIG_SCALE (address 4) and G (address 16_{HEX} of pages 4,5,6,and 7) are set as follows. The values of SCALE and BIG_SCALE must be set to satisfy: $(SCALE + 6 \times BIG_SCALE) \leq (56 - 4\log_2 N)$. N is 128, so $(4\log_2 N)$ is 28. This means $(SCALE + 6 \times BIG_SCALE) \leq 28$, which is satisfied by setting SCALE=4 and BIG_SCALE=4. SCALE, however, needs to be decreased to 3 to prevent overflow in the CFIR, which has a gain of 1.97. The overall gain is set using "G" according to:

$$GAIN = \{ 128^4 \cdot 2^{(27-56)} \} [2^{COARSE}] (1.97) \left(\frac{PFIR_SUM}{65536} \right) \left(\frac{G}{32} \right) = 0.113G$$

Where COARSE is 0 (see Section 7.9) and PFIR_SUM is 240593. The optimal setting of GAIN is 2.0 in order to compensate for the loss in the tuning process (See Section 7.9). A value of G=18 (12_{HEX}) will give a gain of 2.034.

The output serial format is set in address 6 to have a bit rate of one half the chip's clock rate and to be used in the packed mode. The user will need to configure the output format as is necessary for the application.

7.7 DIAGNOSTICS

Four diagnostic tests are described here. These tests use the diagnostic ramp as the input data source and the counter for synchronization. The tests are run by loading the configurations, waiting for the checksum to stabilize, and then reading the checksum from address 15 and comparing it to the expected checksum shown in each configuration table for address 15.

Table 13: Diagnostic Test 1 Configuration

Control Registers		Channel pages 4,5,6,7					Coefficient Pages			
Address	Data	Address	Page 4	Page 5	Page 6	Page 7	Page 8	Page 9	Page 10	Page 11
00 (HEX)	2A (HEX)	10 (HEX)	12 (HEX)	45 (HEX)	AA (HEX)	55 (HEX)	Unused			
01	80	11	23	23	55	AA				
02	07	12	34	34	AA	55				
03	00	13	01	02	00	03				
04	72	14	55	55	55	55				
05	00	15	55	55	55	55				
06	00	16	FF	AA	55	80				
07	00	17	04	04	04	04				
08	51	18	AA	AA	AA	AA				
09	AA	19								
0A	FF	1A								
0B	0F	1B								
0C	88	1C								
0D	0P ²	1D								
0E	00	1E								
0F	85 ¹	1F								

1. This is the read-only expected checksum
 2. P = desired page number

Table 14: Diagnostic Test 2 Configuration

Control Registers		Channel pages 4,5,6,7					Coefficient Pages			
Address	Data	Address	Page 4	Page 5	Page 6	Page 7	Page 8	Page 9	Page 10	Page 11
00 (HEX)	2A (HEX)	10 (HEX)	55 (HEX)	12 (HEX)	45 (HEX)	AA (HEX)	Unused			
01	80	11	AA	23	23	55				
02	0F	12	55	34	34	AA				
03	00	13	03	00	01	02				
04	64	14	AA	AA	AA	AA				
05	00	15	AA	AA	AA	AA				
06	01	16	AA	55	7F	FF				
07	00	17	04	04	04	04				
08	51	18	AA	AA	AA	AA				
09	AA	19								
0A	FF	1A								
0B	0F	1B								
0C	88	1C								
0D	0P	1D								
0E	00	1E								
0F	80 ¹	1F								

1. This is the read-only expected checksum

Table 15: Diagnostic Test 3 Configuration

Control Registers		Channel pages 4,5,6,7					Coefficient Pages			
Address	Data	Address	Page 4	Page 5	Page 6	Page 7	Page 8	Page 9	Page 10	Page 11
00 (HEX)	2A (HEX)	10 (HEX)	12 (HEX)	45 (HEX)	AA (HEX)	55 (HEX)	AA	AA	AA	AA
01	80->82 ²	11	23	23	55	AA	55	55	55	55
02	07	12	34	34	AA	55	AA	AA	AA	AA
03	00	13	00	01	02	03	55	55	55	55
04	72	14	55	55	55	55	AA	AA	AA	AA
05	00	15	55	55	55	55	55	55	55	55
06	00	16	FF	AA	55	80	AA	AA	AA	AA
07	00	17	04	04	04	04	55	55	55	55
08	51	18	AA	AA	AA	AA	AA	AA	AA	AA
09	AA	19					55	55	55	55
0A	FF	1A					AA	AA	AA	AA
0B	0F	1B					55	55	55	55
0C	88	1C					AA	AA	AA	AA
0D	0P	1D					55	55	55	55
0E	00	1E					AA	AA	AA	AA
0F	BA ¹	1F					55	55	55	55
1. This is the read-only expected checksum 2. Initialize to 80, then set to 82 after coefficients have been loaded										

Table 16: Diagnostic Test 4 Configuration

Control Registers		Channel pages 4,5,6,7					Coefficient Pages			
Address	Data	Address	Page 4	Page 5	Page 6	Page 7	Page 8	Page 9	Page 10	Page 11
00 (HEX)	2A (HEX)	10 (HEX)	55 (HEX)	12 (HEX)	45 (HEX)	AA (HEX)	55	55	55	55
01	80->82 ²	11	AA	23	23	55	AA	AA	AA	AA
02	FF	12	55	34	34	AA	55	55	55	55
03	00	13	03	00	01	02	AA	AA	AA	AA
04	40	14	AA	AA	AA	AA	55	55	55	55
05	00	15	AA	AA	AA	AA	AA	AA	AA	AA
06	00	16	AA	55	7F	FF	55	55	55	55
07	00	17	04	04	04	04	AA	AA	AA	AA
08	51	18	AA	AA	AA	AA	55	55	55	55
09	AA	19					AA	AA	AA	AA
0A	FF	1A					55	55	55	55
0B	0F	1B					AA	AA	AA	AA
0C	88	1C					55	55	55	55
0D	0P	1D					AA	AA	AA	AA
0E	00	1E					55	55	55	55
0F	D2 ¹	1F					AA	AA	AA	AA
1. This is the read-only expected checksum 2. Initialize to 80, then set to 82 after coefficients have been loaded										

7.8 OUTPUT TEST CONFIGURATION

The following configuration allows the user to debug the output interface to insure that the GC4014 data is being received properly by the following circuitry. The configuration in the following table will generate a fixed output sequence of four values (two complex pairs) which will repeat indefinitely:

Table 17: Output Test Configuration

Control Registers		Channel pages 4,5,6,7	
Address	Data	Address	Data
00 (HEX)	6A (HEX) ¹	10 (HEX)	00 (HEX)
01	81	11	00
02	0F ²	12	00
03	00 ²	13	00
04	63 ²	14	00
05	00	15	00
06	11 ³	16	80
07	10	17	74
08	50	18	FF
09	AA	19	
0A	FF	1A	
0B	FF	1B	
0C	0F	1C	
0D	0P ⁴	1D	
0E	00	1E	
0F	read only	1F	

1. Initialize to 6A while configuring the chip(s), then set to EA, then back to 6A to fire off the one-shot sync.
 2. Gives an overall decimate by 64. See Table 18 for other values.
 3. Value is application dependent.
 4. "P" is the page number. The upper nibble should stay at "0".

The programmable PFIR coefficients are not used and do not need to be loaded. The user should change address 6 (Output Format Register) to reflect the desired serial or link output mode. The expected results for various decimation ratios are shown below:

Table 18: Test Output Sequence

Decimation Controls			Output Sequence			
Overall Decimation	Addresses 2, 3	Address 4	I ₀	Q ₀	I ₁	Q ₁
32	07, 00	71	8000	FD00	7F00	0300
64	0F, 00	63				
128	1F, 00	55				
256	3F, 00	51				
512	7F, 00	43				
1024	FF, 00	35				
2048	FF, 01	31				
100	18, 00	60	8000	FE00	7F00	0200

The output sequence is the same for all power-of-two decimations. Other decimation ratios, with the SCALE and BIG_SCALE values being the maximum which satisfy: $(SCALE + 6 \times BIG_SCALE) \leq (56 - 4\log_2 N)$, will result in sequences with the same I values, but with slightly different Q values.

7.9 OPTIMAL GAIN SETTINGS

The overall gain of the chip is the product of the CIC gain, the coarse gain, the CFIR gain, the PFIR gain and the final gain. Each of these components are:

$$\text{CIC gain} = N^4 2^{(\text{SCALE} + 6 \times \text{BIG_SCALE} - 56)}$$

$$\text{Coarse gain} = 2^{\text{COARSE}}$$

$$\text{CFIR gain} = (1.0 + \text{NARROW} \times 0.97)$$

$$\text{PFIR gain} = \frac{\text{PFIR_SUM}}{65536}$$

$$\text{Final gain} = \frac{G}{32}$$

The signal flows through these sections in the order given. The gain settings which optimize the dynamic range of the chip, are the ones that maximize the signal amplitude without clipping at the output of each of these processing stages. A conservative approach to gain would be to set each gain component so that the product of the gains at each processing point in the flow is less than or equal to unity.

The conservative approach, described above, is usually less than optimal. The optimal gain takes the following considerations into account.

7.9.1 Tuning Loss

The input to the chip can be described as a signal $S(t)$ modulated to a center frequency of "w". The input is, therefore, $S(t)\cos(wt) = S(t)(e^{j\omega t} + e^{-j\omega t})/2$. If the downconverter tunes to the frequency "w", then the tuner output will be $S(t)(1.0 + e^{-2\omega t})/2$. The filters will then reject the component at "-2w", leaving just the signal $S(t)/2$. This loss of one-half amplitude can be compensated for by setting the overall gain equal to 2, not unity. The tuning gain loss occurs after the CIC filters, so the optimum gain approach is to use gain settings that keep the gain product after the coarse, CFIR, PFIR and final gain stages equal to 2.

7.9.2 Uniform Power Inputs

The gain can be further optimized if the user has control over the power levels of the signals in the input bands. If all of the signals in the input are close to equal power, then the gain of the downconverted signal can be boosted to maximize its dynamic range. For example, if there are "M" signals of equal power in the input band, then the amplitude of each signal is $\frac{1}{\sqrt{M}}$. This means that the gain can be boosted by a factor of \sqrt{M} within the downconverter. The coarse gain can be used to add the additional gain.

Examples of applications which can use this feature are FM-FDM systems, cellular systems which use power control, and wireless local loop systems that fix the power level of each remote transmitter.

Page left intentionally blank

PACKAGING INFORMATION

Orderable Device	Status ⁽¹⁾	Package Type	Package Drawing	Pins	Package Qty	Eco Plan ⁽²⁾	Lead/Ball Finish	MSL Peak Temp ⁽³⁾
GC4014-PQ	OBSOLETE	LQFP	PZ	100		TBD	Call TI	Call TI

⁽¹⁾ The marketing status values are defined as follows:

ACTIVE: Product device recommended for new designs.

LIFEBUY: TI has announced that the device will be discontinued, and a lifetime-buy period is in effect.

NRND: Not recommended for new designs. Device is in production to support existing customers, but TI does not recommend using this part in a new design.

PREVIEW: Device has been announced but is not in production. Samples may or may not be available.

OBSOLETE: TI has discontinued the production of the device.

⁽²⁾ Eco Plan - The planned eco-friendly classification: Pb-Free (RoHS) or Green (RoHS & no Sb/Br) - please check <http://www.ti.com/productcontent> for the latest availability information and additional product content details.

TBD: The Pb-Free/Green conversion plan has not been defined.

Pb-Free (RoHS): TI's terms "Lead-Free" or "Pb-Free" mean semiconductor products that are compatible with the current RoHS requirements for all 6 substances, including the requirement that lead not exceed 0.1% by weight in homogeneous materials. Where designed to be soldered at high temperatures, TI Pb-Free products are suitable for use in specified lead-free processes.

Green (RoHS & no Sb/Br): TI defines "Green" to mean Pb-Free (RoHS compatible), and free of Bromine (Br) and Antimony (Sb) based flame retardants (Br or Sb do not exceed 0.1% by weight in homogeneous material)

⁽³⁾ MSL, Peak Temp. -- The Moisture Sensitivity Level rating according to the JEDEC industry standard classifications, and peak solder temperature.

Important Information and Disclaimer:The information provided on this page represents TI's knowledge and belief as of the date that it is provided. TI bases its knowledge and belief on information provided by third parties, and makes no representation or warranty as to the accuracy of such information. Efforts are underway to better integrate information from third parties. TI has taken and continues to take reasonable steps to provide representative and accurate information but may not have conducted destructive testing or chemical analysis on incoming materials and chemicals. TI and TI suppliers consider certain information to be proprietary, and thus CAS numbers and other limited information may not be available for release.

In no event shall TI's liability arising out of such information exceed the total purchase price of the TI part(s) at issue in this document sold by TI to Customer on an annual basis.

PZ (S-PQFP-G100)

PLASTIC QUAD FLATPACK

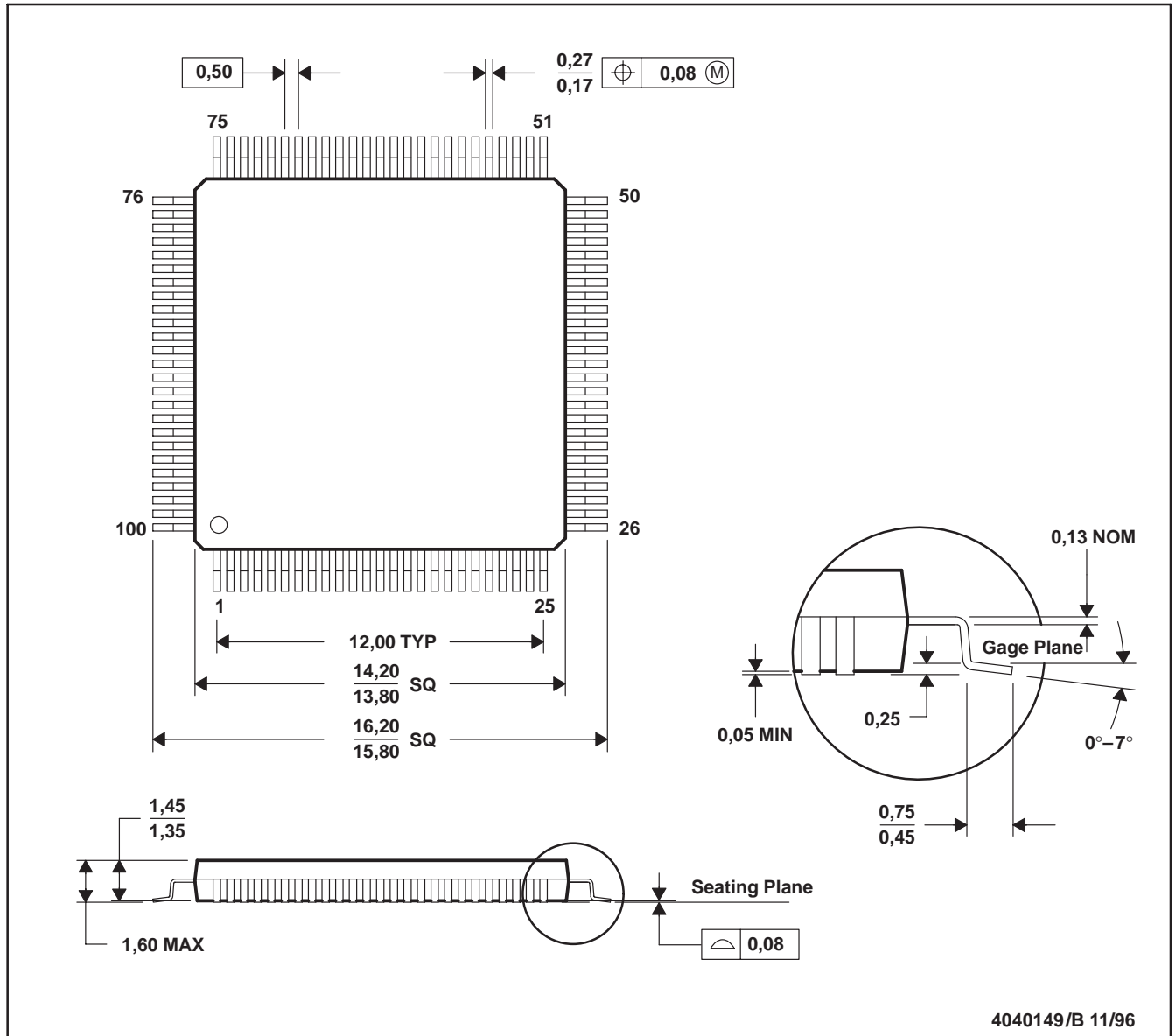

- NOTES: A. All linear dimensions are in millimeters.
 B. This drawing is subject to change without notice.
 C. Falls within JEDEC MS-026

IMPORTANT NOTICE

Texas Instruments Incorporated and its subsidiaries (TI) reserve the right to make corrections, modifications, enhancements, improvements, and other changes to its products and services at any time and to discontinue any product or service without notice. Customers should obtain the latest relevant information before placing orders and should verify that such information is current and complete. All products are sold subject to TI's terms and conditions of sale supplied at the time of order acknowledgment.

TI warrants performance of its hardware products to the specifications applicable at the time of sale in accordance with TI's standard warranty. Testing and other quality control techniques are used to the extent TI deems necessary to support this warranty. Except where mandated by government requirements, testing of all parameters of each product is not necessarily performed.

TI assumes no liability for applications assistance or customer product design. Customers are responsible for their products and applications using TI components. To minimize the risks associated with customer products and applications, customers should provide adequate design and operating safeguards.

TI does not warrant or represent that any license, either express or implied, is granted under any TI patent right, copyright, mask work right, or other TI intellectual property right relating to any combination, machine, or process in which TI products or services are used. Information published by TI regarding third-party products or services does not constitute a license from TI to use such products or services or a warranty or endorsement thereof. Use of such information may require a license from a third party under the patents or other intellectual property of the third party, or a license from TI under the patents or other intellectual property of TI.

Reproduction of TI information in TI data books or data sheets is permissible only if reproduction is without alteration and is accompanied by all associated warranties, conditions, limitations, and notices. Reproduction of this information with alteration is an unfair and deceptive business practice. TI is not responsible or liable for such altered documentation. Information of third parties may be subject to additional restrictions.

Resale of TI products or services with statements different from or beyond the parameters stated by TI for that product or service voids all express and any implied warranties for the associated TI product or service and is an unfair and deceptive business practice. TI is not responsible or liable for any such statements.

TI products are not authorized for use in safety-critical applications (such as life support) where a failure of the TI product would reasonably be expected to cause severe personal injury or death, unless officers of the parties have executed an agreement specifically governing such use. Buyers represent that they have all necessary expertise in the safety and regulatory ramifications of their applications, and acknowledge and agree that they are solely responsible for all legal, regulatory and safety-related requirements concerning their products and any use of TI products in such safety-critical applications, notwithstanding any applications-related information or support that may be provided by TI. Further, Buyers must fully indemnify TI and its representatives against any damages arising out of the use of TI products in such safety-critical applications.

TI products are neither designed nor intended for use in military/aerospace applications or environments unless the TI products are specifically designated by TI as military-grade or "enhanced plastic." Only products designated by TI as military-grade meet military specifications. Buyers acknowledge and agree that any such use of TI products which TI has not designated as military-grade is solely at the Buyer's risk, and that they are solely responsible for compliance with all legal and regulatory requirements in connection with such use.

TI products are neither designed nor intended for use in automotive applications or environments unless the specific TI products are designated by TI as compliant with ISO/TS 16949 requirements. Buyers acknowledge and agree that, if they use any non-designated products in automotive applications, TI will not be responsible for any failure to meet such requirements.

Following are URLs where you can obtain information on other Texas Instruments products and application solutions:

Products

Amplifiers	amplifier.ti.com
Data Converters	dataconverter.ti.com
DSP	dsp.ti.com
Clocks and Timers	www.ti.com/clocks
Interface	interface.ti.com
Logic	logic.ti.com
Power Mgmt	power.ti.com
Microcontrollers	microcontroller.ti.com
RFID	www.ti-rfid.com
RF/IF and ZigBee® Solutions	www.ti.com/lprf

Applications

Audio	www.ti.com/audio
Automotive	www.ti.com/automotive
Broadband	www.ti.com/broadband
Digital Control	www.ti.com/digitalcontrol
Medical	www.ti.com/medical
Military	www.ti.com/military
Optical Networking	www.ti.com/opticalnetwork
Security	www.ti.com/security
Telephony	www.ti.com/telephony
Video & Imaging	www.ti.com/video
Wireless	www.ti.com/wireless

Mailing Address: Texas Instruments, Post Office Box 655303, Dallas, Texas 75265
Copyright 2008, Texas Instruments Incorporated